

# **TOYOTA**

## **ELECTRICAL WIRING DIAGRAM**

---

**1986 MODEL**

## **FOREWORD**

This wiring diagram has been prepared to provide information on the electrical system of the 1986 TOYOTA COROLLA FR AE86L series.

All information in the manual is based on the latest product information at the time of publication. However, specifications and procedures are subject to change without notice.

**TOYOTA MOTOR CORPORATION**

# 1986 TOYOTA COROLLA FR ELECTRICAL WIRING DIAGRAM

|   |    |
|---|----|
| INTRODUCTION .....                          | A  |
| HOW TO USE THIS MANUAL .....                | B  |
| TROUBLESHOOTING .....                       | C  |
| GLOSSARY OF TERMS AND SYMBOLS .....         | D  |
| POWER SOURCE .....                          | 1  |
| STARTING AND IGNITION SYSTEM .....          | 2  |
| CHARGING SYSTEM .....                       | 3  |
| EFI SYSTEM .....                            | 4  |
| EMISSION CONTROL .....                      | 5  |
| IDLE-UP .....                               | 6  |
| HEADLIGHTS .....                            | 7  |
| STOP LIGHTS .....                           | 8  |
| TAILLIGHTS AND ILLUMINATION .....           | 9  |
| BACK-UP LIGHTS .....                        | 10 |
| INTERIOR LIGHTS .....                       | 11 |
| TURN SIGNAL AND HAZARD WARNING LIGHTS ..... | 12 |
| LIGHT AUTO TURN OFF SYSTEM .....            | 13 |
| FRONT WIPERS AND WASHER .....               | 14 |
| REAR WIPER AND WASHER .....                 | 15 |
| OVERDRIVE .....                             | 16 |
| SEAT BELT WARNING .....                     | 17 |
| POWER WINDOW .....                          | 18 |
| REAR WINDOW DEFOGGER .....                  | 19 |
| REMOTE CONTROL MIRRORS .....                | 20 |
| CRUISE CONTROL .....                        | 21 |
| CIGARETTE LIGHTER AND CLOCK .....           | 22 |
| SUN ROOF .....                              | 23 |
| RADIO AND HORN .....                        | 24 |
| COMBINATION METER .....                     | 25 |
| AIR CONDITIONER .....                       | 26 |
| GROUND POINTS .....                         | 27 |
| RELAY LOCATIONS .....                       |    |
| ELECTRICAL WIRING ROUTING .....             |    |
| OVER ALL ELECTRICAL WIRING DIAGRAM .....    |    |

1985 TOYOTA MOTOR CORPORATION

All rights reserved. This book may not be reproduced or copied, in whole or in part, without the written permission of Toyota Motor Corporation.

# A INTRODUCTION

This manual is composed of the following 5 elements.

|              |                |               |                                 |                         |
|--------------|----------------|---------------|---------------------------------|-------------------------|
| Power Source | System Circuit | Ground Points | Relay Location & Wiring Routing | Over all Wiring Diagram |
|--------------|----------------|---------------|---------------------------------|-------------------------|

Circuit from battery to each fuse

Each circuit classified by system

Relation between ground points of each component

Relay & Connector location

Shows relation between each system

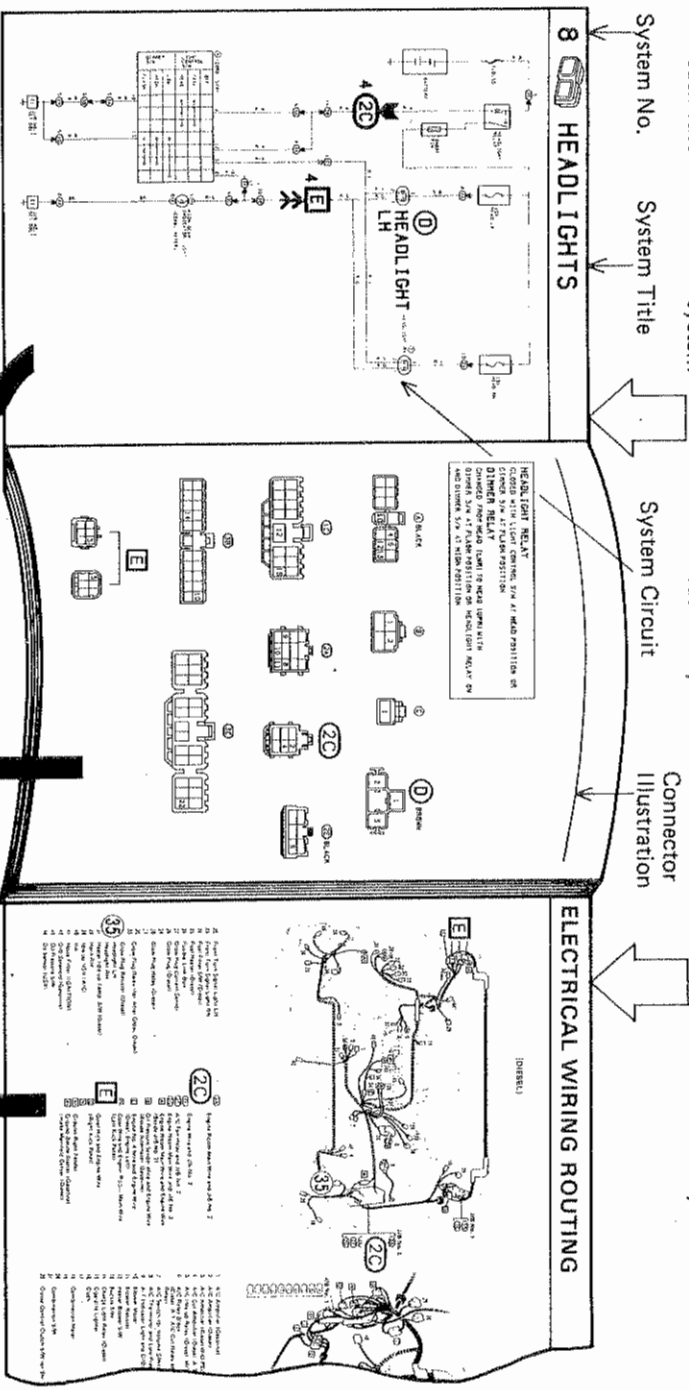

| Components | Circuit | Connector | Location   |
|------------|---------|-----------|--|
|            |         |           | <b>35</b> Headlight LH<br>Wiring routing components listed in alphabetical order |
|            |         |           | <b>2C</b> Engine Room Main Wire & Junction Block No. 2                           |
|            |         |           | <b>E</b> Engine Room Main Wire & Cowl Wire                                       |

Note: The number indicates the number of the junction block.  
(Wire Harness Side)

# 14 REAR WINDOW DEFOGGER

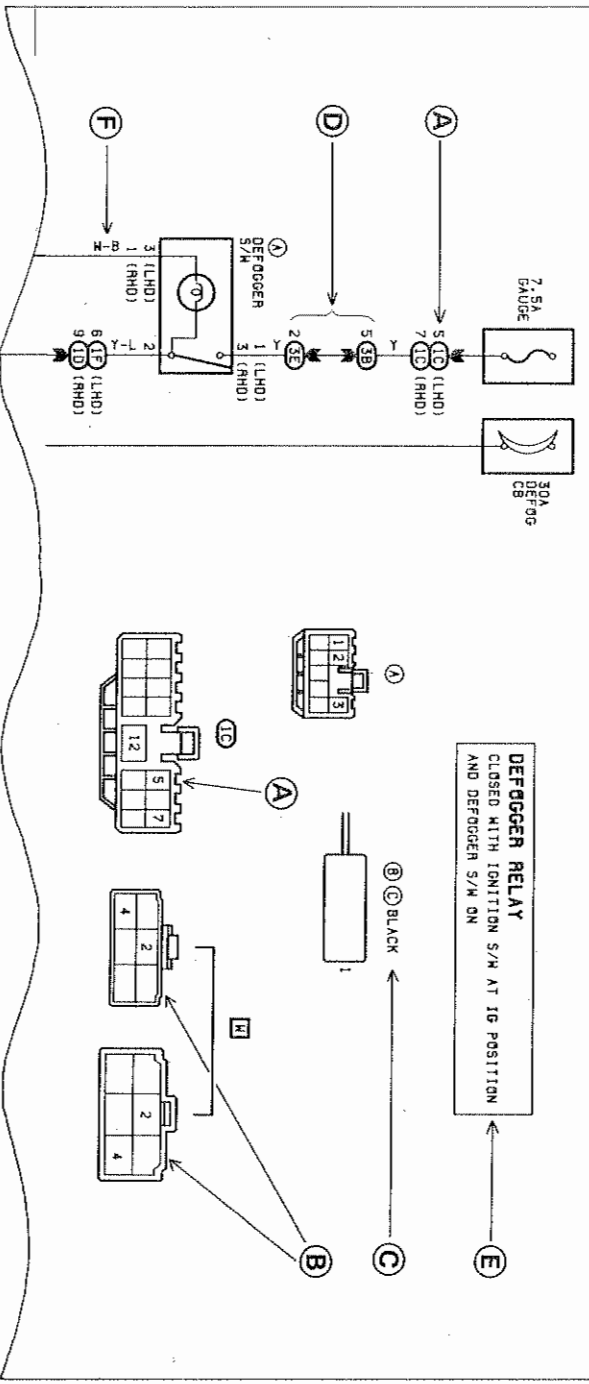

**A** Pin Number  
 Numbered in order from upper left to lower right

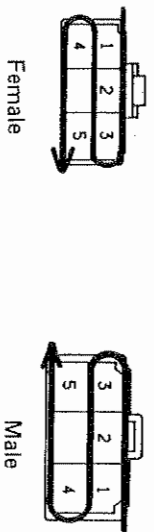

**D** Indicates circuit in Junction Block No. 3.  
 Example:

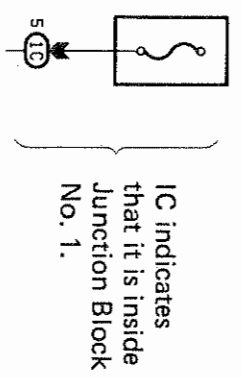

**B** Male & female connectors distinguished by shape of their internal pins.  
 • All connectors are shown from the open end, and the lock is on top.

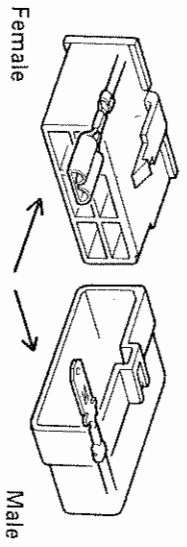

**C** Connector Color  
 Connectors not indicated are milky white in color.

**E** Troubleshooting Hints & Components Operation

**F** Wire Color  
 Wire colors are indicated by an alphabetical code.

B = Black    L = Light Blue    R = Red  
 BR = Brown    LG = Light Green    V = Violet  
 G = Green    O = Orange    W = White  
 GR = Grey    P = Pink    Y = Yellow

The first letter indicates the basic wire color and the second letter indicates the color of the stripe.



**ABBREVIATIONS**  
 The following abbreviations are used in this manual.

- |                              |                                    |                              |
|------------------------------|------------------------------------|------------------------------|
| A/C = Air Conditioner        | IIA = Integrated Ignition Assembly | RH = Right-hand              |
| A/T = Automatic Transmission | J/B = Junction Block               | S/W = Switch                 |
| CB = Circuit Breaker         | LH = Left-hand                     | VSV = Vacuum Switching Valve |
| CMH = Cold Mixture Heater    | O/D = Overdrive                    | W/ = With                    |
| FL = Fusible Link            | OVCV = Outer Vent Control Valve    | W/O = Without                |

## B HOW TO USE THIS MANUAL

To better understand how to use this manual, let's assume that the headlights will not light, and go through an actual troubleshooting procedure.

### CONFIRMATION OF TROUBLE

Turn on the headlight switch and check for yourself that the headlights do not come on.

### READ THE CIRCUIT DIAGRAM

1. Locate the headlight system number in the index and open the manual to the page indicated. (The system number is written in bold at the top corner of each page).
2. Read the circuit diagram to learn how it works.
3. Unfold the ELECTRICAL WIRING ROUTING page at the back of the manual.

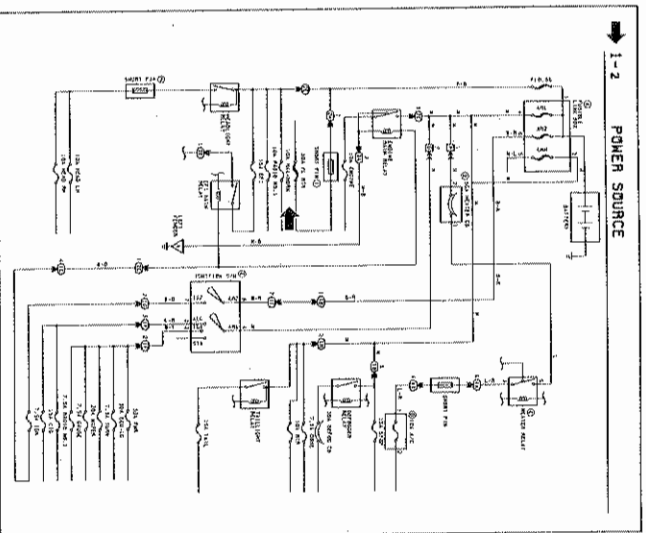

### PINPOINT THE TROUBLE

If the circuit is in common with others (power circuit or ground point), problems will occur in some of the others also. Please refer to **POWER SOURCE** (System No, 1-2). Since the headlights are related to the **HAZ-HORN**, check this circuit.

Okay . . . . . Trouble lies within the headlight circuit.  
Bad . . . . . Check circuits in common.

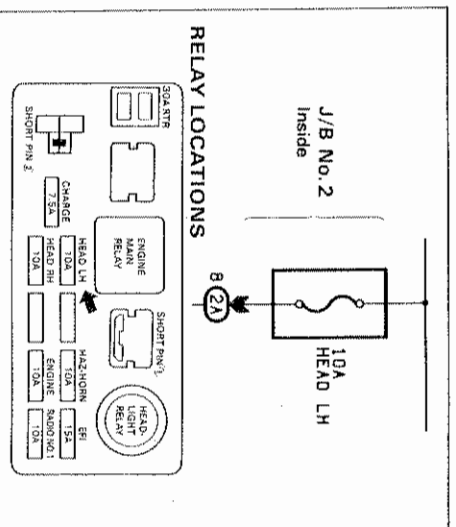

1. Inspection of Headlight Circuit (Return to **HEADLIGHT** page.)

#### (a) Check Headlight Fuse

- ① According to **(2A)** of the circuit, the headlight fuse is in J/B No. 2.
- ② The location of J/B No. 2 can be found by referring to the **RELAY LOCATIONS** page just before the **ELECTRICAL WIRING ROUTING** page.

#### ③ Check if either fuse is blown.

- (b) Check if there is power to pin No. 8 of **(2A)**.
  - ① Turn the light control switch to **HEAD**.
  - ② Using a voltmeter, check for voltage as shown below.

Negative (—) Probe . . . . . Good ground point or negative battery terminal.  
Positive (+) Probe . . . . . Pin No. 8 of **(2A)**.

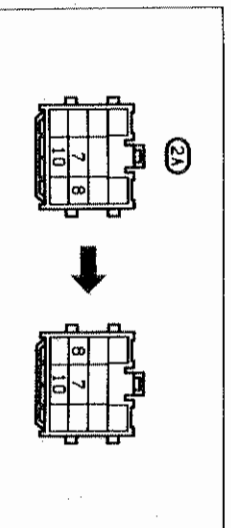

Battery Voltage . . . . . Trouble is past pin No. 8 of **(2A)**  
 No Battery Voltage . . . . . Trouble is before pin No. 8 of **(2A)** .

**CAUTION:**

Insert the tester probes from the wire harness side of the connector. Consequently, note that the pin numbers will be in reverse order of that shown in the illustration.

(c) Check if there is power to the headlights.

- ① From the circuit we can see that **(C)** is the headlight connector and that there is power from pin No. 3 to 2 when the headlights are at high beam.
- ② Turn the light control switch to **HEAD**.
- ③ Place the dimmer switch at **HI**.
- ④ Using a voltmeter, check for voltage as shown below.

{ Negative (-) probe . . . Pin No. 2 of connector **(C)** .  
 Positive (+) probe . . . . Pin No. 3 of connector **(C)** .

Voltage . . . . . Trouble is in the headlight.  
 No Voltage . . . . . Probable defective ground past pin No.2 so make contact with negative lead to a good ground point or battery negative terminal and check for voltage.

Voltage . . . . . Trouble is past pin No. 2 of **(C)**  
 No Voltage . . . . . Trouble is before pin No. 3 of **(C)** .

**CAUTION:**

Do not check for continuity while voltage is applied or it may result in damage to the tester.

(d) To check the low beam, place the dimmer switch at **LOW** and perform the check in the same sequence.

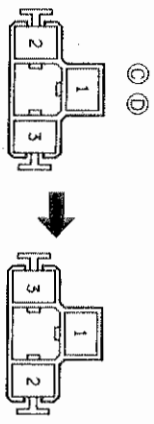
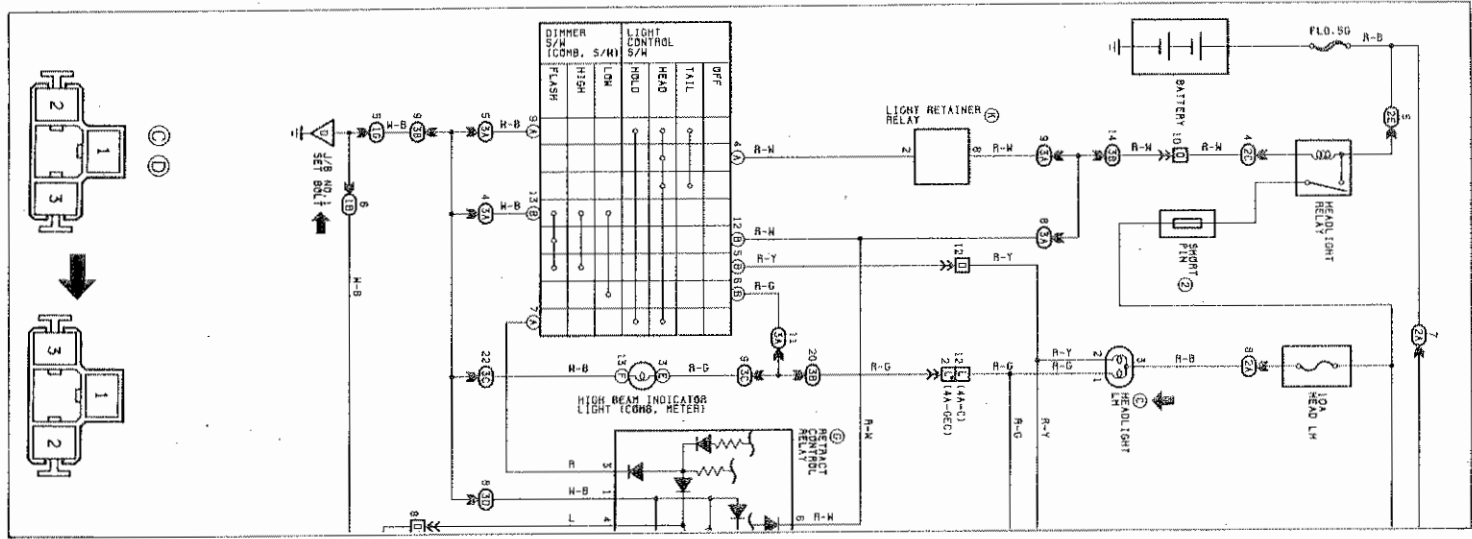

**ELECTRICAL WIRING ROUTING**

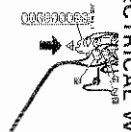

- 1. Check for continuity between the ground point and the battery negative terminal.
- 2. Check for continuity between the ground point and the battery negative terminal.
- 3. Check for continuity between the ground point and the battery negative terminal.
- 4. Check for continuity between the ground point and the battery negative terminal.
- 5. Check for continuity between the ground point and the battery negative terminal.
- 6. Check for continuity between the ground point and the battery negative terminal.
- 7. Check for continuity between the ground point and the battery negative terminal.
- 8. Check for continuity between the ground point and the battery negative terminal.
- 9. Check for continuity between the ground point and the battery negative terminal.
- 10. Check for continuity between the ground point and the battery negative terminal.
- 11. Check for continuity between the ground point and the battery negative terminal.
- 12. Check for continuity between the ground point and the battery negative terminal.
- 13. Check for continuity between the ground point and the battery negative terminal.
- 14. Check for continuity between the ground point and the battery negative terminal.
- 15. Check for continuity between the ground point and the battery negative terminal.
- 16. Check for continuity between the ground point and the battery negative terminal.
- 17. Check for continuity between the ground point and the battery negative terminal.
- 18. Check for continuity between the ground point and the battery negative terminal.
- 19. Check for continuity between the ground point and the battery negative terminal.
- 20. Check for continuity between the ground point and the battery negative terminal.
- 21. Check for continuity between the ground point and the battery negative terminal.
- 22. Check for continuity between the ground point and the battery negative terminal.
- 23. Check for continuity between the ground point and the battery negative terminal.
- 24. Check for continuity between the ground point and the battery negative terminal.
- 25. Check for continuity between the ground point and the battery negative terminal.
- 26. Check for continuity between the ground point and the battery negative terminal.
- 27. Check for continuity between the ground point and the battery negative terminal.
- 28. Check for continuity between the ground point and the battery negative terminal.
- 29. Check for continuity between the ground point and the battery negative terminal.
- 30. Check for continuity between the ground point and the battery negative terminal.
- 31. Check for continuity between the ground point and the battery negative terminal.
- 32. Check for continuity between the ground point and the battery negative terminal.

(e) Check ground point

- 1 The ground point is indicated by the **(V)** J/B No. 1 SET BOLT in the circuit.
- 2 The location of the ground point on the vehicle can be found by referring to the same symbol **(V)** in ELECTRICAL WIRING ROUTING.

# B HOW TO USE THIS MANUAL

| 1-1 POWER SOURCE (Power—Load Rete) |   |
|------------------------------------|---|
| J/B No. 2 (Engine Room)            | Load  |
| 10A HEAD LH                        | Headlight LH  |
| 10A HEAD RH                        | Headlight RH  |
| 10A ENGINE                         | Alternator, Charge Light Relay (4A-C)<br>Fuel Cut Solenoid, Emission Control Cam<br>EBCV, CMT Relay, Secondary Slow Out |
| 10A RADIO NO. 1                    | Radio and Tape Player   |
| 10A HAZ-HORN                       | Horn<br>Hazard SW, Turn Signal Flasher  |

## 2. Inspection of Common Circuits

- (a) Check battery and fusible link
- (b) Check related systems  
Check how the HEAD FUSE is related to the system.  
In system No. 1-1 (POWER SOURCE), you will find a chart listing the relationship between the fuses and components. Here we can see that the HEAD fuses are related only to their respective headlights.

(c) Check the circuit from the battery to the HEAD FUSE.

- ① In system No. 1-2 (POWER SOURCE), the power circuits for all fuses are listed. The circuit between the battery and HEAD fuse branches off with fuses HAZ-HORN 10A etc.
- ② Turn on the HAZARD switch

Okay . . . . . No trouble in circuit up to HAZ-HORN junction.  
Bad . . . . . Trouble lies between fusible link and J/B No. 2.

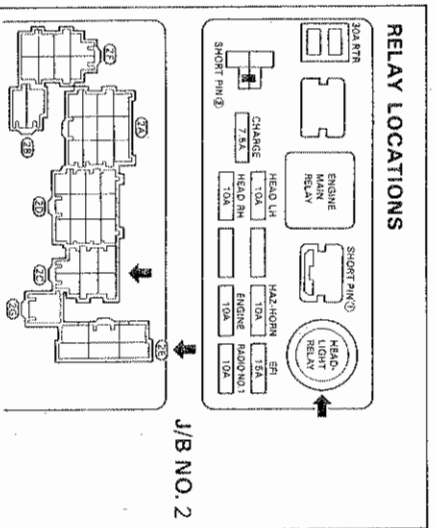
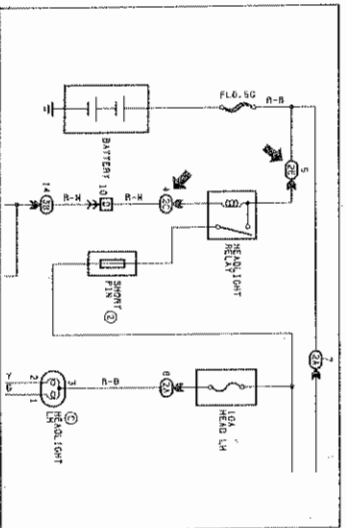
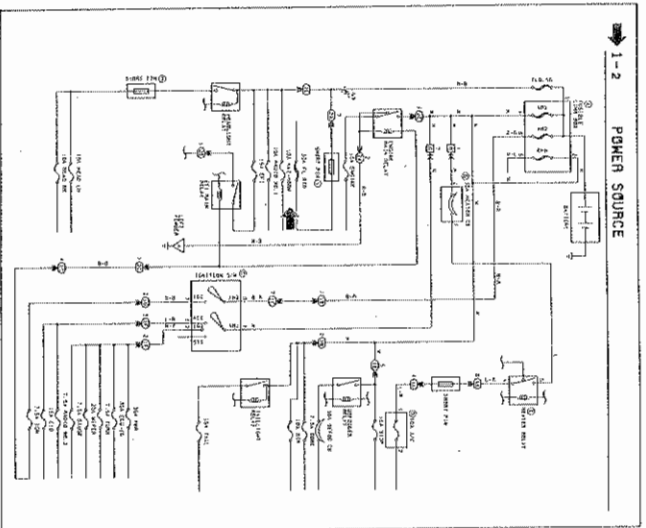

(d) Check the HEADLIGHT RELAY  
(Return to HEADLIGHT page)

- 1 The circuit shows that the HEADLIGHT RELAY is in J/B No. 2.
- 2 Installation of the relay can be found by referring to the RELAY LOCATIONS. The HEADLIGHT RELAY is located in J/B No. 2 in the engine compartment as shown.
- 3 Check for power to the headlight relay coil.
  - ① Turn the headlight switch to HEAD.
  - ② Using a voltmeter, check for voltage as shown below.

Negative (-) Probe . . . . . Pin No. 4 of ②C  
Positive (+) Probe . . . . . Pin No. 5 of ②E

Confirm that there is voltage



- 4 Next, check if the headlight relay points are closed and there is power to the pin No. 8 of (22). See step 1-(b)

If no voltage, trouble lies in the headlight relay.

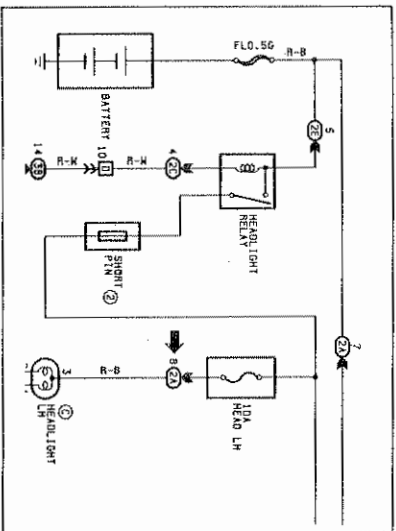

- (e) Check which systems (components) have the same ground point.

The ground points are listed in system No. 27 (GROUND POINTS). As shown, GROUND POINT (27) is used for other components besides the HEADLIGHT SYSTEM, and it also connected to GROUND POINT (27).

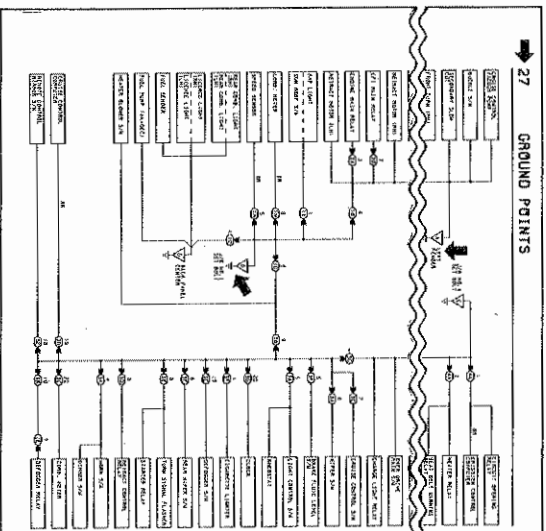

- (f) Check how the HEADLIGHT SYSTEM is connected to the other systems.

1 From the EWD SYSTEM INDEX (facing the first EWD), we can find the location of the headlight system within the ELECTRICAL WIRING DIAGRAM at the back of the book (Page 3 of 4, grid 7 and 8).

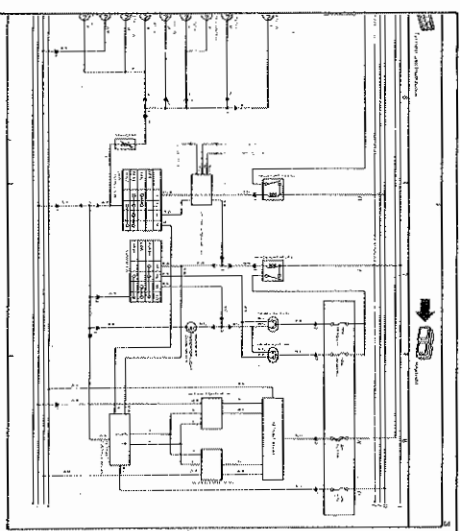
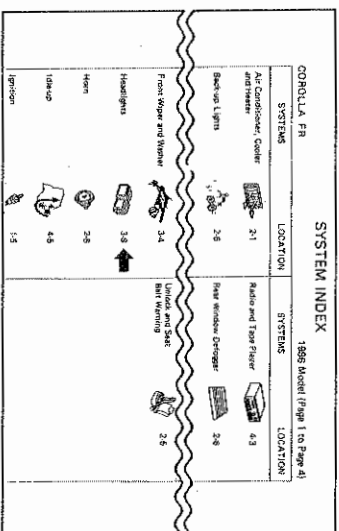

2 By referring to the ELECTRICAL WIRING DIAGRAM, we can see that the HEADLIGHT SYSTEM is related to the TAIL and ILLUMINATION SYSTEM.

**NOTE:**

The relationship between system circuits is not shown so always confirm with the overall wiring diagram.

- (g) Re-check

After repair, check that the circuit functions normally. Always follow the steps described above to narrow down the possible range of the trouble.

## C TROUBLESHOOTING

### TROUBLESHOOTING PROCEDURE

1. Determine what is wrong with the system.
2. First read the diagram so you understand the system. Refer to the component operation boxed within the system circuit.
3. Locate the cause of the problem.
  - a. Determine whether the problem is with the common circuit (power source or ground) or individual circuit.  
Check other loads or switches which are in parallel with the problem component.  
If they are normal, the problem lies within the particular system itself.  
Refer to the **POWER SOURCE** or **GROUND POINTS** and check the related systems.  
(NOTE: Each component is grounded at 2 or 3 points.)  
If the related systems are normal, the common circuit (power source or ground points) is okay.  
The problem lies within the individual system.
  - b. Locate the exact point of the problem by narrowing down the area with a voltmeter or test lamp.
4. Repair and re-check the circuit.  
If any wiring was disconnected for troubleshooting, reconnect it and check the related circuits.

### VOLTAGE CHECK

1. Establish conditions in which voltage is present at the check point.  
(Refer to component operations.)

Example:

- Ⓐ — Ignition S/W on
- Ⓑ — Ignition S/W and S/W 1 on
- Ⓒ — Ignition S/W, S/W 1 and Relay on (S/W 2 off)

2. Using a voltmeter, connect the negative lead to a good ground point or negative battery terminal and the positive lead to the connector or component terminal. This check can be done with a test lamp instead of a voltmeter.

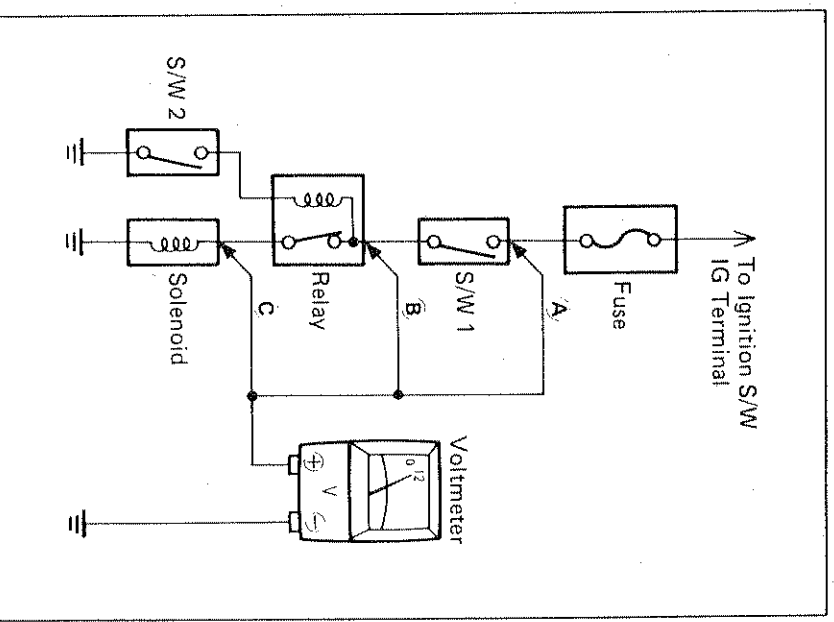

## CONTINUITY AND RESISTANCE CHECK

1. Disconnect the battery terminal or wire so there is no voltage between the check points.
2. Contact the two leads of an ohmmeter to each of the check points.

If the circuit has diodes, reverse the two leads and check again.

When contacting the negative lead to the diode positive side and the positive lead to the negative side, there should be continuity.

When contacting the two leads in reverse, there should be no continuity.

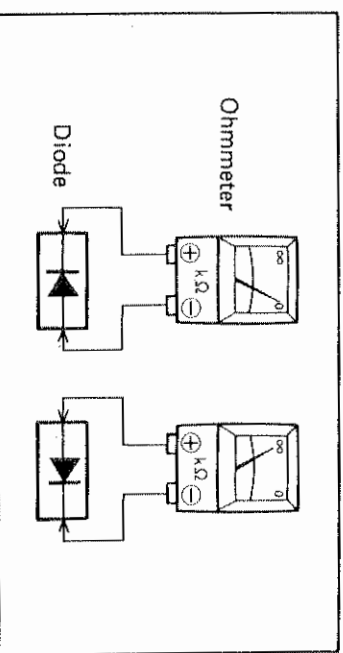
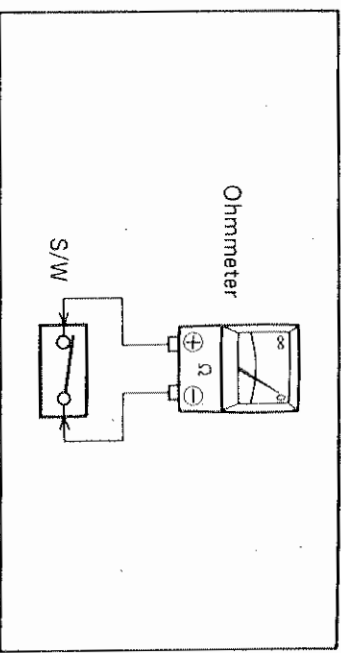

## FINDING A SHORT CIRCUIT

1. Remove the blown fuse and disconnect all loads of the fuse.
2. Connect a test lamp in place of the fuse.
3. Establish conditions in which the test lamp comes on. (Refer to component operations.)

Example:

- Ⓐ — Ignition S/W on
- Ⓑ — Ignition S/W and S/W 1 on
- Ⓒ — Ignition S/W, S/W 1 and Relay on (Connect the Relay) and S/W 2 off (or Disconnect S/W 2)







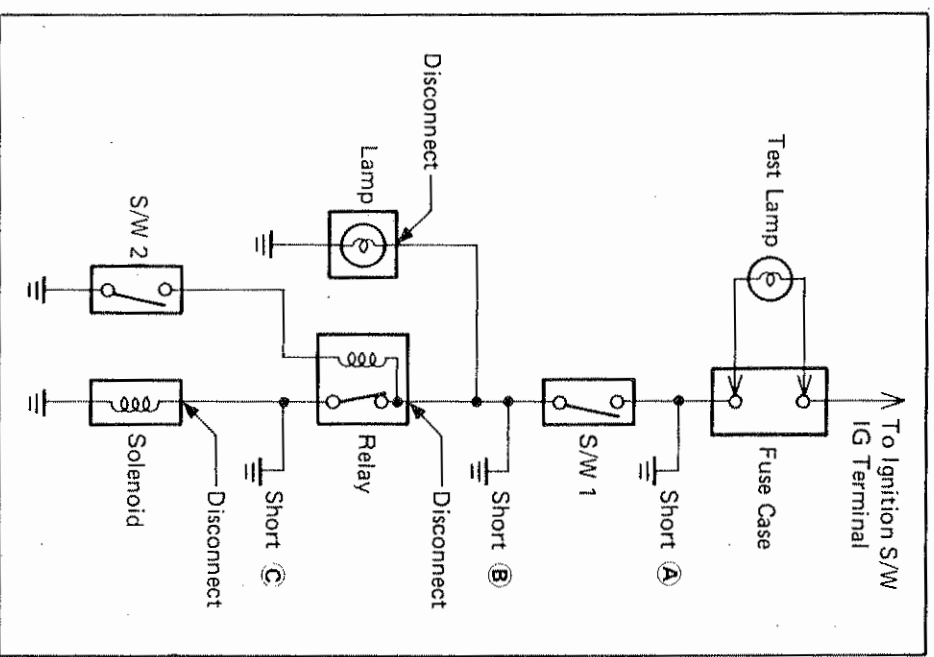



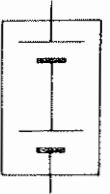
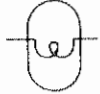

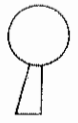

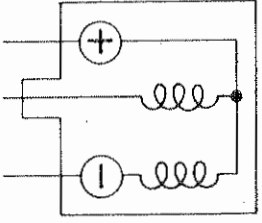
4. Disconnect and reconnect the connectors while watching the test lamp.



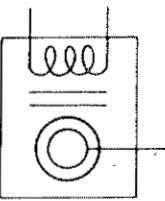



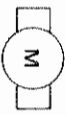

The short lies between the connector where the test lamp stays lit and the connector where the lamp goes out.

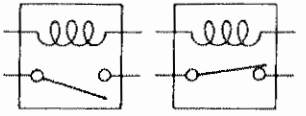
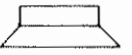
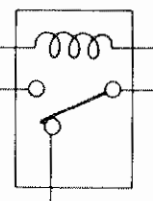
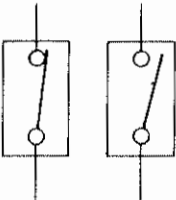
5. Find the exact location of the short by lightly shaking the problem wire along the body.

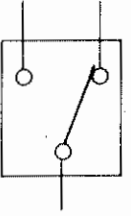

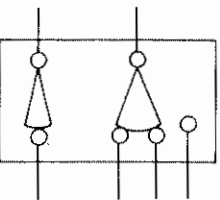
# D GLOSSARY OF TERMS AND SYMBOLS

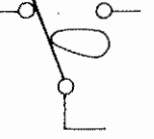
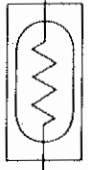
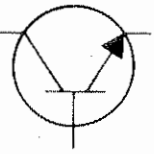
|  |   |
|--|---|
|  <p><b>BATTERY</b><br/>Stores chemical energy and converts it into electrical energy. Provides DC current for the auto's various electrical circuits.</p>   |  <p><b>HEADLIGHTS</b><br/>1. SINGLE FILAMENT<br/>2. DOUBLE FILAMENT</p> <p>Current flow causes a headlight filament to heat up and emit light. A headlight may have either a single (1) filament or a double (2) filament.</p> |
|  <p><b>CAPACITOR (Condenser)</b><br/>A small holding unit for temporary storage of electrical voltage. Capacitors with a ground connection are frequently called Condensers.</p>  |  <p><b>HORN</b><br/>An electric device which sounds a loud audible signal.</p>   |
|  <p><b>CIGARETTE LIGHTER</b><br/>An electric resistance heating element.</p>  |  <p><b>IGNITION COIL</b><br/>Converts low-voltage DC current into high-voltage ignition current for firing the spark plugs.</p>   |
|  <p><b>CIRCUIT BREAKER</b><br/>Basically a reusable fuse, a circuit breaker will heat and open if too much current flows through it. Some units automatically reset when cool, others must be manually reset.</p>                     |  <p><b>DIODE</b><br/>A semiconductor which allows current flow in only one direction.</p>  |
|  <p><b>DIODE, ZENER</b><br/>A diode which allows current flow in one direction but blocks reverse flow only up to a specific voltage. Above that potential, it passes the excess voltage. This acts as a simple voltage regulator.</p> |  <p><b>LIGHT</b><br/>Current flow through a filament causes the filament to heat up and emit light.</p>  |
|  <p><b>DISTRIBUTOR, I/A</b><br/>Channels high-voltage current from the ignition coil to the individual spark plugs.</p>   |  <p><b>LED (LIGHT EMITTING DIODE)</b><br/>Upon current flow, these diodes emit light without producing the heat of a comparable light. Used in instrument displays.</p>  |
|  <p><b>FUSE</b><br/>A thin metal strip which burns through when too much current flows through it, thereby stopping current flow and protecting a circuit from damage.</p>  |  <p><b>METER, ANALOG</b><br/>Current flow activates a magnetic coil which causes a needle to move, thereby providing a relative display against a background calibration.</p>  |
|  <p><b>FUSIBLE LINK</b><br/>A heavy-gauge wire placed in high amperage circuits which burns through on overloads, thereby protecting the circuit.</p>   |  <p><b>METER, DIGITAL</b><br/>Current flow activates one or many LED's, LCD's, or fluorescent displays, which provide a relative or digital display.</p>   |
|  <p><b>GROUND</b><br/>The point at which wiring attaches to the chassis, thereby providing a return path for an electrical circuit; without a ground, current cannot flow.</p>  |  <p><b>MOTOR</b><br/>A power unit which converts electrical energy into mechanical energy, especially rotary motion.</p>   |

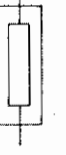
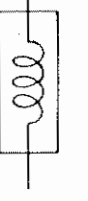
|  |  |
|--|--|
| <p><b>RELAY</b></p>  <p><b>1. NORMALLY CLOSED</b><br/>Basically, an electrically operated switch which may be normally closed (1) or open (2). Current flow through a small coil creates a magnetic field which either opens or closes an attached switch.</p> <p><b>2. NORMALLY OPEN</b></p>                    |  <p><b>SPEAKER</b></p> <p>An electromechanical device which creates sound waves from current flow.</p>  |
| <p><b>RELAY, DOUBLE THROW</b></p>  <p>A relay which passes current through one set of contacts or the other.</p>   | <p><b>SWITCH, MANUAL</b> Opens and closes circuits, thereby stopping (1) or allowing (2) current flow.</p>  <p><b>1. NORMALLY OPEN</b></p> <p><b>2. NORMALLY CLOSED</b></p>   |
| <p><b>RESISTOR</b></p>  <p>An electrical component with a fixed resistance, placed in a circuit to reduce voltage to a specific value.</p>  | <p><b>SWITCH, DOUBLE THROW</b></p>  <p>A switch which continuously passes current through one set of contacts or the other.</p>   |
| <p><b>RESISTOR, TAPPED</b></p>  <p>A resistor which supplies two or more different non-adjustable resistance values.</p>  | <p><b>SWITCH, IGNITION</b></p>  <p>A key operated switch with several positions which allow various circuits. Particularly the primary ignition circuit, to become operational.</p>  |
| <p><b>RESISTOR, VARIABLE or RHEOSTAT</b></p>  <p>A controllable resistor with a variable rate of resistance. Also called a potentiometer or rheostat.</p>  | <p><b>SWITCH, WIPER PARK</b></p>  <p>Automatically returns wipers to the stop position when the wiper switch is turned off.</p>   |
| <p><b>SENSOR (Thermistor)</b></p>  <p>A resistor which varies its resistance with temperature.</p>  | <p><b>TRANSISTOR</b></p>  <p>A solidstate device typically used as an electronic relay; stops or passes current depending on the applied voltage at "base".</p>   |
| <p><b>SENSOR, ANALOG SPEED</b></p>  <p>Uses magnetic impulses to open and close a switch to create a signal for activation of other components.</p>   | <p><b>WIRES</b></p> <p><b>1. NOT CONNECTED</b></p>  <p>Wires are always drawn as straight lines on wiring diagrams. Crossed wires (1) without a black dot at the junction are not joined; crossed wires (2) with a black dot at the junction are spliced (joined) connections.</p> <p><b>2. SPLICED</b></p> |
| <p><b>SHORT PIN</b></p>  <p>Used to provide an unbroken connection within a junction block.</p> <p><b>SOLENOID</b></p>  <p>An electromagnetic coil which creates a magnetic field upon current flow, to move a plunger, etc.</p> |  |

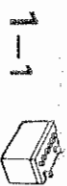

# 1-1 POWER SOURCE (Power—Load Reference)

## J/B No. 1 (Left Kick Panel)

| Power | Load   | System No. |
|-------|--|------------|
| 7.5A  | Digital Clock  | 22         |
|       | Interior Light, Map Light, Door Warning Light, Luggage Room Light  | 11         |
|       | Light Retainer Relay   | 13         |
| 30A   | Unlock Warning S/W, Seat Belt Relay  | 17         |
|       | Sun Roof Motor   | 23         |
| 7.5A  | Radio and Tape Player  | 24         |
|       | Remote Control Mirrors   | 20         |
| 15A   | Cigarette Lighter, Digital Clock   | 22         |
| 7.5A  | Turn Signal Flasher, Turn Signal Light, Turn Signal S/W  | 12         |
|       | Combination Meter  | 25         |
|       | Back-up Light S/W, Back-up Light   | 10         |
|       | O/D Relay, O/D Off Indicator   | 16         |
|       | Defogger S/W, Defogger Relay   | 19         |
|       | Light Retainer Relay   | 13         |
|       | Heater Relay   | 26         |
|       | Cruise Control S/W   | 21         |
|       | Seat Belt Warning Relay, Seat Belt Warning Light   | 17         |
|       | Engine Main Relay  | 1          |
| 7.5A  | EFI Main Relay   | 4          |
|       | Charge Warning Light   | 3          |
|       | Washer Motor, Wiper Motor  | 14         |
| 20A   | Rear Wiper Motor, Rear Washer Motor  | 15         |
|       | Stop Light S/W, Stop Light   | 8          |
| 15A   | Cruise Control Computer  | 21         |
|       | ECU  | 4          |
| 10A   | Retract Control Relay  | 7          |
| 15A   | Clearance Light, Taillight, Licence Plate Light, Radio Light, Cigarette Lighter Light, Heater Control Light, Combination Meter Light, A/T Indicator Light, Side Marker Light O/D MAIN S/W Light, Wiper S/W Light, Defogger S/W Light | 9          |
|       | Digital Clock  | 22         |
|       |  |            |
| 30A   | Rear Window Defogger   | 19         |
| 30A   | Power Window Relay   | 18         |

**J/B No.2 (Engine Room)**

| Power | Load  | System No. |
|-------|---|------------|
| 10A   | HEAD LH   | 7          |
| 10A   | HEAD RH   | 7          |
| 10A   | Headlight RH  | 7          |
| 10A   | Alternator, Charge Light Relay (4A-C)   | 3          |
| 10A   | Fuel Cut Solenoid, Emission Control Computer, OVCV, EBCV, CMH Relay, Secondary Slow Cut | 5          |
| 10A   | Radio and Tape Player   | 24         |
| 10A   | Horn  | 24         |
| 10A   | Hazard S/W, Turn Signal Flasher   | 12         |
| 7.5A  | Charge Warning Light, Charge Light Relay  | 3          |
|       | Choke Heater  | 5          |
| 30A   | Retract Relay   | 7          |
| 15A   | EFI Main Relay, ECU, Circuit Opening Relay  | 4          |

**J/B No.4 (Right Kick Panel)**

|     |           |                            |    |
|-----|-----------|----------------------------|----|
| 10A | A/C       | A/C S/W, A/C Amplifier     | 26 |
| 30A | HEATER CB | Heater Relay, Blower Motor | 26 |

**Fusible Link Box (Battery ⊕ Terminal)**

|                                      |        |                                       |    |
|--------------------------------------|--------|---------------------------------------|----|
| 80A<br>(4A-<br>GEC)<br>60A<br>(4A-C) | FL AM1 | Engine Main Relay, Ignition S/W (AM1) | 1  |
|                                      |        | Alternator                            | 3  |
|                                      |        | Defogger Relay                        | 19 |
|                                      |        | Taillight Relay                       | 9  |
| 30A                                  | FL AM2 | Ignition S/W (AM2)                    | 1  |
| 40A                                  | FL CMH | CMH, CMH Relay                        | 5  |

**Fusible Link (Near the Battery)**

|         |                 |   |
|---------|-----------------|---|
| FL 0.5G | Headlight Relay | 7 |
|---------|-----------------|---|

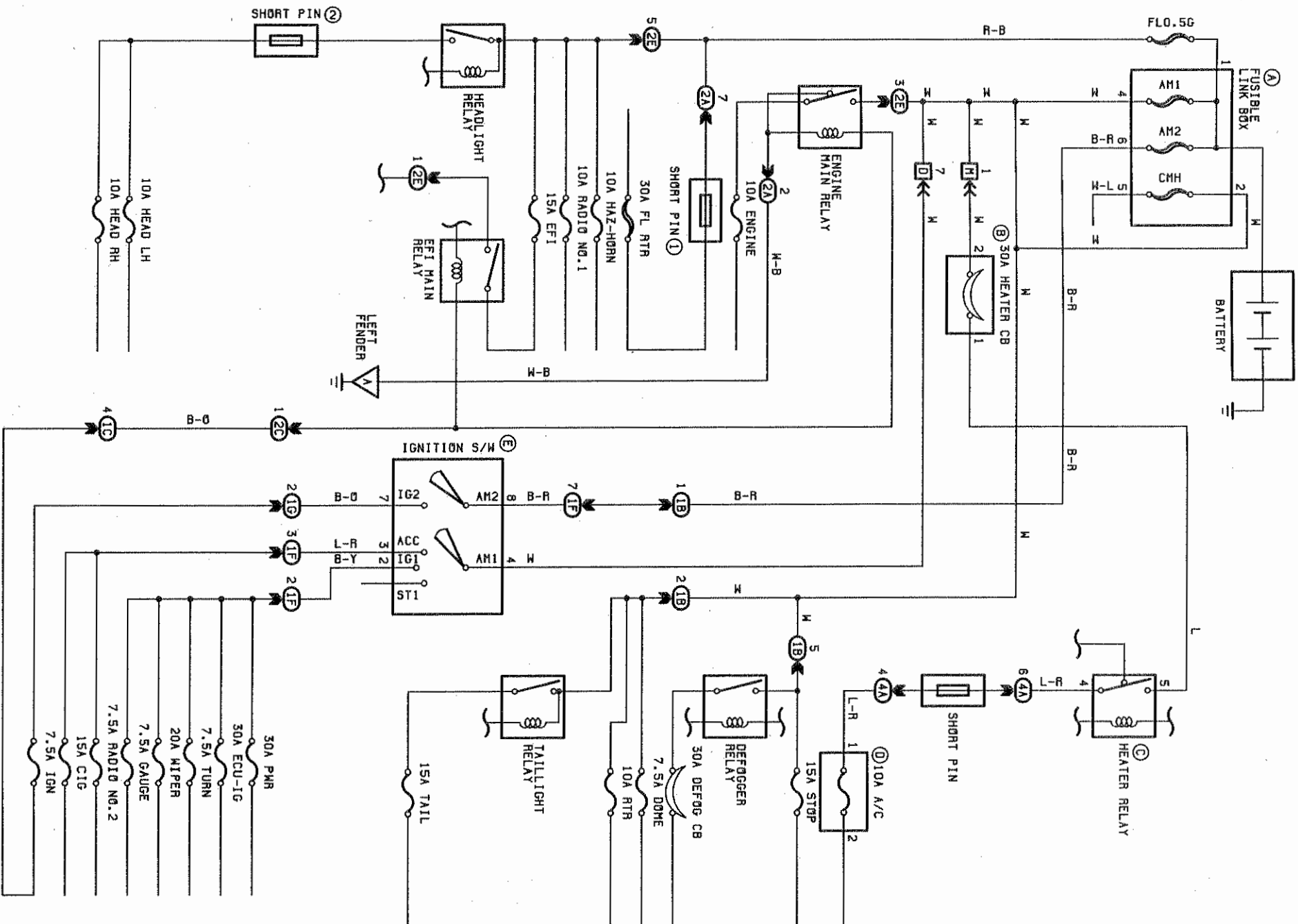



**(A) FUSIBLE LINK BOX**

AM1: 80A(4A-C), 80A(4A-GEC)  
 AM2: 50A  
 CMH: 40A

**TAILLIGHT RELAY**

CLOSED WITH LIGHT CONTROL S/W AT TAIL OR HEAD POSITION

**ENGINE MAIN RELAY**

CHANGED WITH IGNITION S/W AT IG OR ST POSITION

**HEADLIGHT RELAY**

CLOSED WITH LIGHT CONTROL S/W AT HEAD POSITION  
 OR DIMMER S/W AT FLASH POSITION

**EFI MAIN RELAY**

CLOSED WITH IGNITION S/W ON

**(C) HEATER RELAY**

4-5: CLOSED WITH IGNITION S/W ON AND BLOWER S/W ON

**DEFROGGER RELAY**

CLOSED WITH IGNITION S/W AT IG POSITION  
 AND DEFROGGER S/W ON

**(E) IGNITION S/W**

4-3: CLOSED WITH IGNITION KEY AT ACC OR IG POSITION

4-2: CLOSED WITH IGNITION KEY AT IG OR ST POSITION

8-7: CLOSED WITH IGNITION KEY AT IG OR ST POSITION

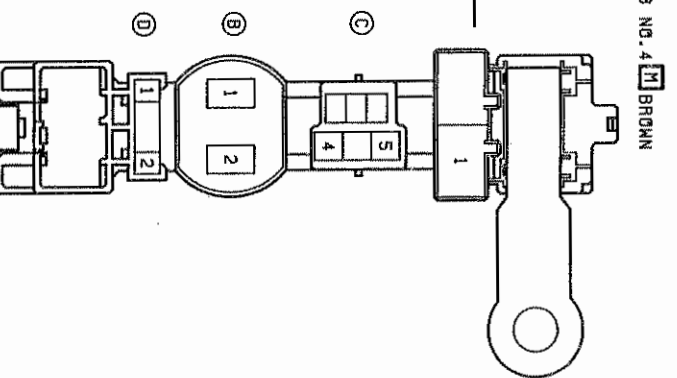
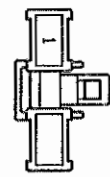
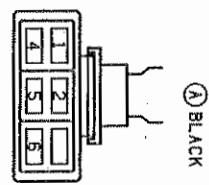

**(E) BLACK**

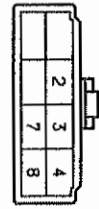

**(B) BLACK**

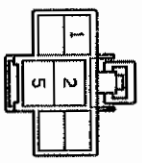

**(C)**

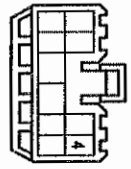

**(F) ORANGE**

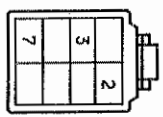

**(G)**

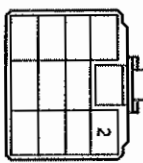

**(2A)**

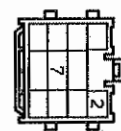

**(2C)**

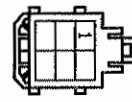

**(2E) BLACK**

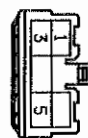

**(4A)**

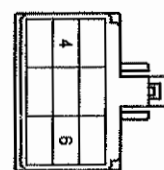

**(D)**

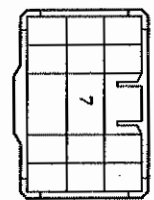
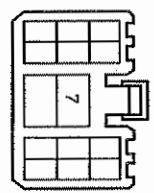



## 2 STARTING AND IGNITION SYSTEMS

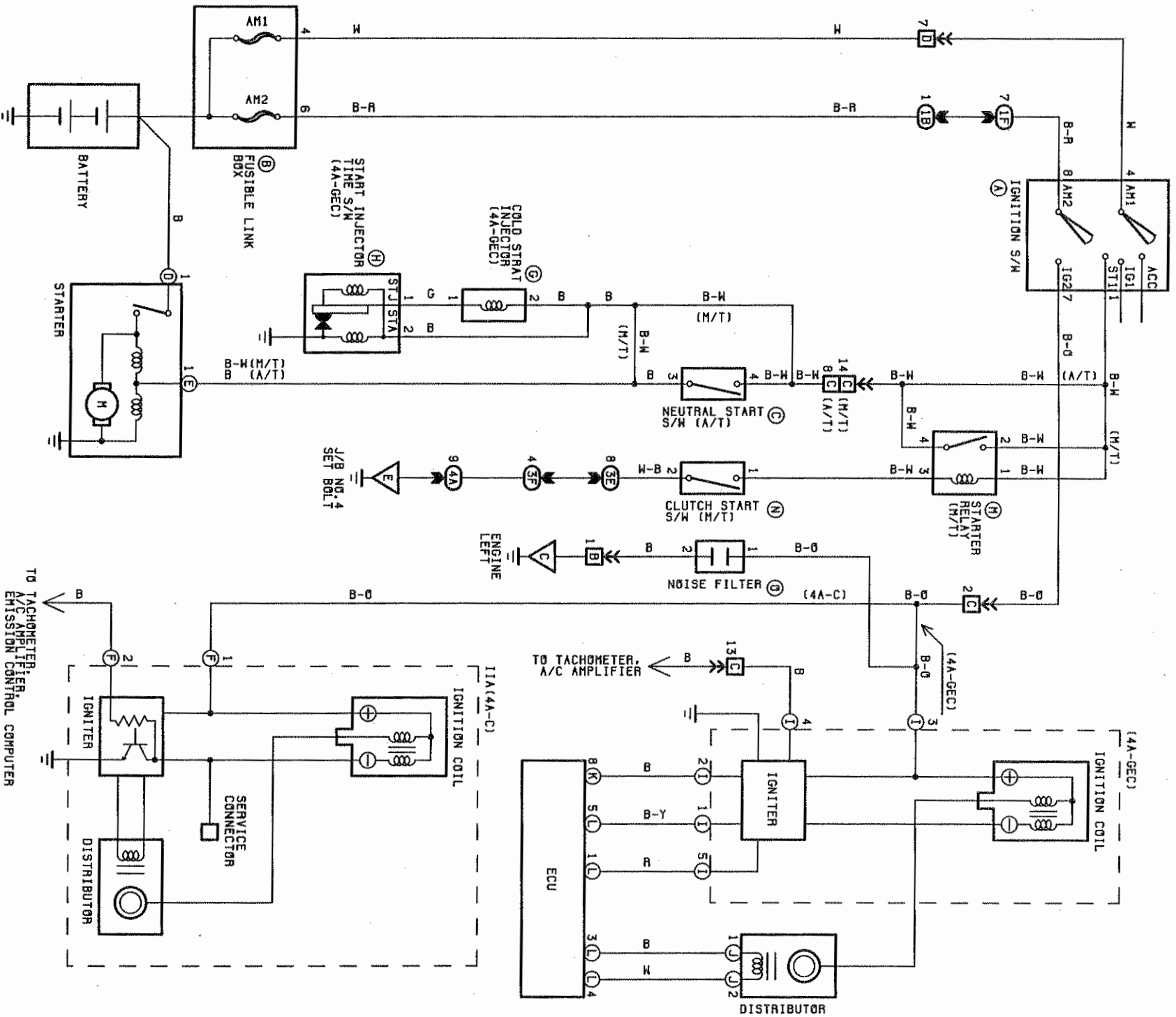

|   |  |
|---|--|
| <p><b>(A) IGNITION S/W</b><br/>         4-11: CLOSED WITH IGNITION S/W AT ST POSITION<br/>         8-7: CLOSED WITH IGNITION S/W AT IG OR ST POSITION</p> <p><b>(B) FUSIBLE LINK BOX</b><br/>         AN1: 50A (4A-C), 80A(4A-GEC)<br/>         AN2: 50A</p> <p><b>(C) NEUTRAL START S/W (A/T)</b><br/>         CLOSED WITH A/T SHIFT LEVER IN P OR N POSITION</p> <p><b>STARTER</b><br/>         POINTS CLOSED WITH NEUTRAL START S/W ON (A/T) AND IGNITION S/W AT ST POSITION</p> | <p><b>(D) COLD START INJECTOR (4A-GEC)</b><br/>         1-2: 12 VOLTS WHILE START INJECTOR TIME S/W POINT IS CLOSED AND STATER CRANKING</p> <p><b>(H) START INJECTOR TIME S/W (4A-GEC)</b><br/>         POINT OPEN MORE THAN 35°C (95°F)<br/>         2-1: 20-40Ω BELOW 30°C (86°F)<br/>         40-60Ω ABOVE 40°C (104°F)<br/>         2-GROUND: 20-80Ω</p> <p><b>(N) STARTER RELAY</b><br/>         2-4: CLOSED WITH CLUTCH START S/W ON AND IGNITION S/W AT ST POSITION</p> <p><b>(N) CLUTCH START S/W</b><br/>         1-2: CLOSED WITH CLUTCH PEDAL FULLY DEPRESSED</p> |
|---|--|

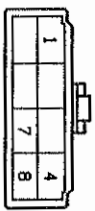

(A) BLACK

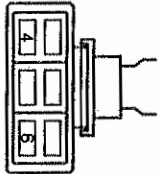

(B) BLACK

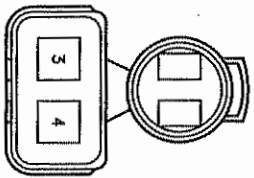

(C)



(D)



(E) BLACK

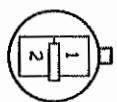

(F) GREEN

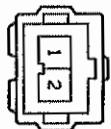

(G) BLACK

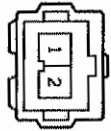

(H) BROWN

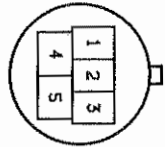

(I) GREEN

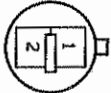

(J) GREEN

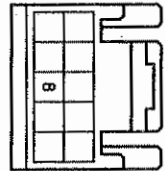

(K) YELLOW

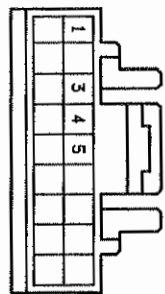

(L) YELLOW

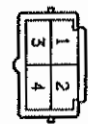

(M)

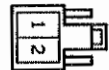

(N)

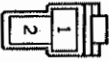

(O) BLUE

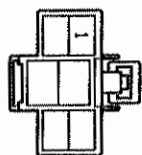

(P) BLACK

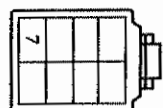

(Q) ORANGE

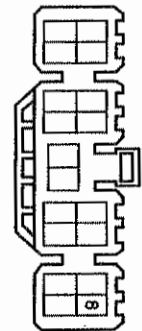

(R)

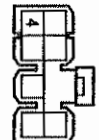

(S)

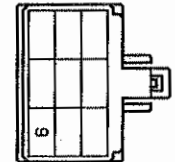

(T)



(U)



(V)

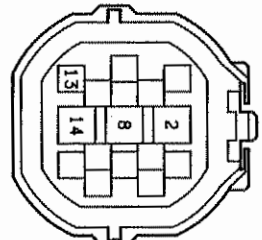

(W) BLACK

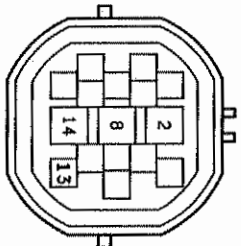

(X) BLACK

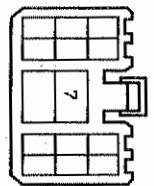

(Y)

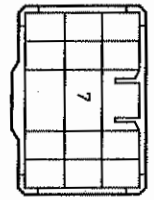

# CHARGING SYSTEM

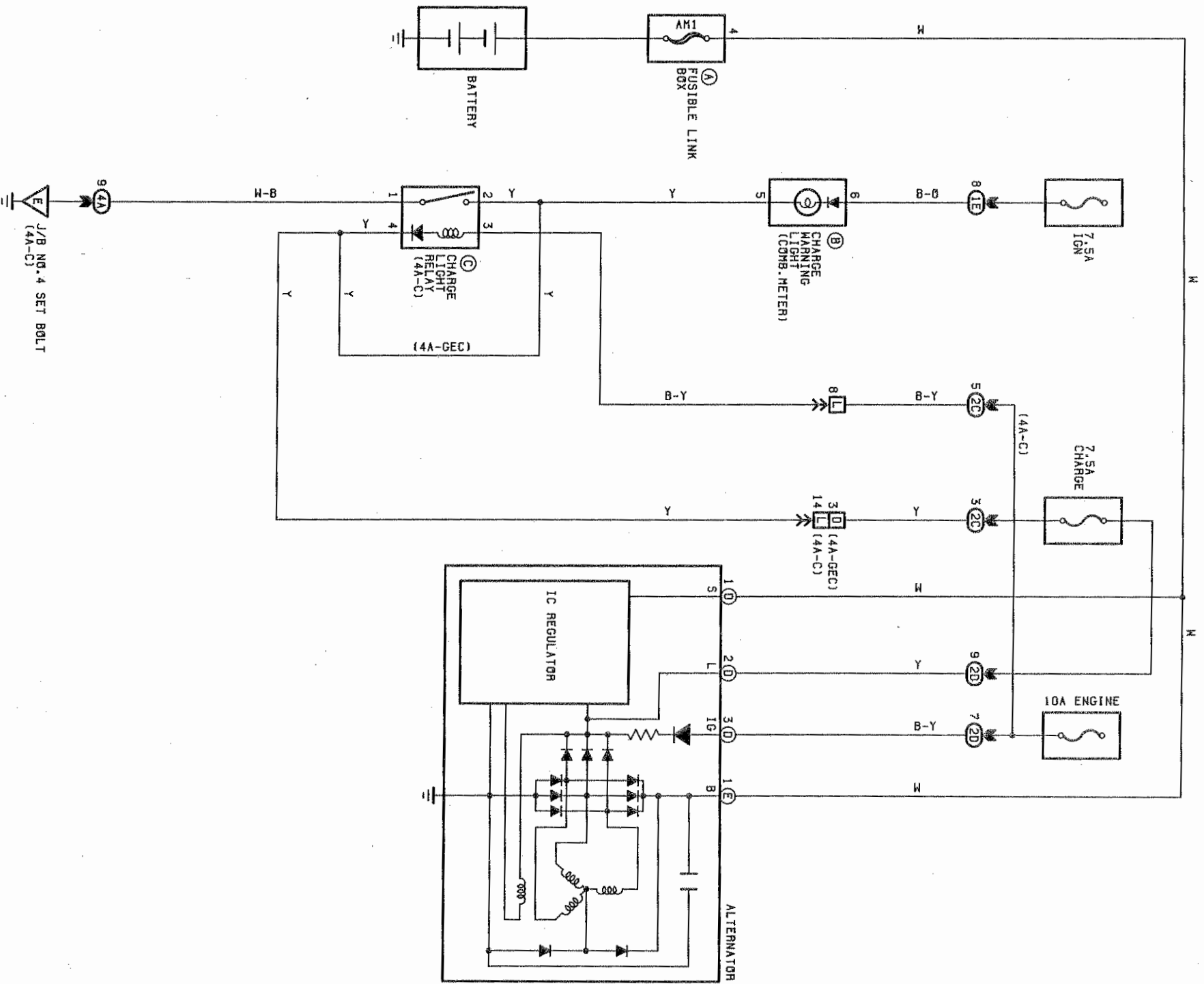

**Ⓒ CHARGE LIGHT RELAY (4A-C)**

OPEN WITH ALTERNATOR CHARGING  
(4-GROUND: MORE THAN 10 VOLTS)  
CLOSED WITH ALTERNATOR NOT CHARGING  
(4-GROUND: LESS THAN 10 VOLTS)

**ALTERNATOR**

- Ⓓ 1-GROUND: 13.5-14.5 VOLTS WITH ENGINE RUNNING AT 2000 RPM
- Ⓔ 2-GROUND: 0-4 VOLTS WITH IGNITION S/W AT 1<sup>st</sup> POSITION AND ENGINE NOT RUNNING

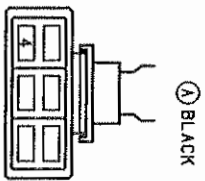

Ⓐ BLACK

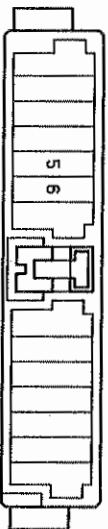

Ⓑ BLUE

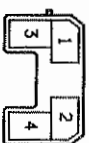

Ⓒ

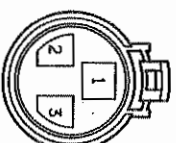

Ⓓ BLACK



Ⓔ

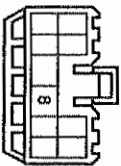

1E

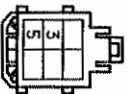

2C

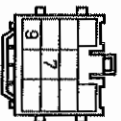

2D ORANGE

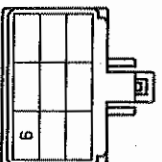

4A

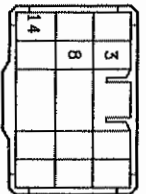
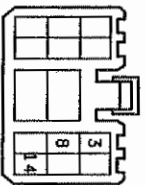

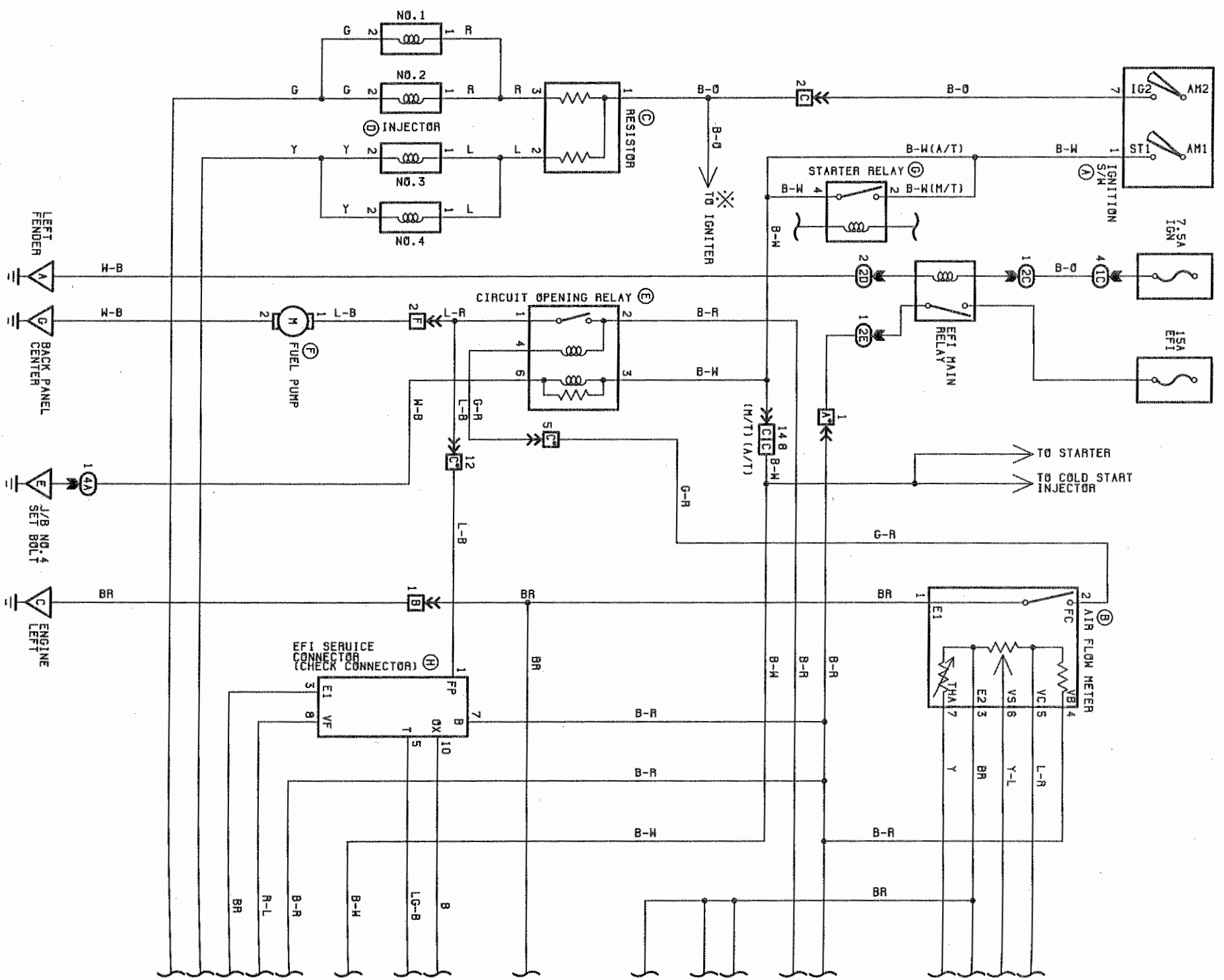

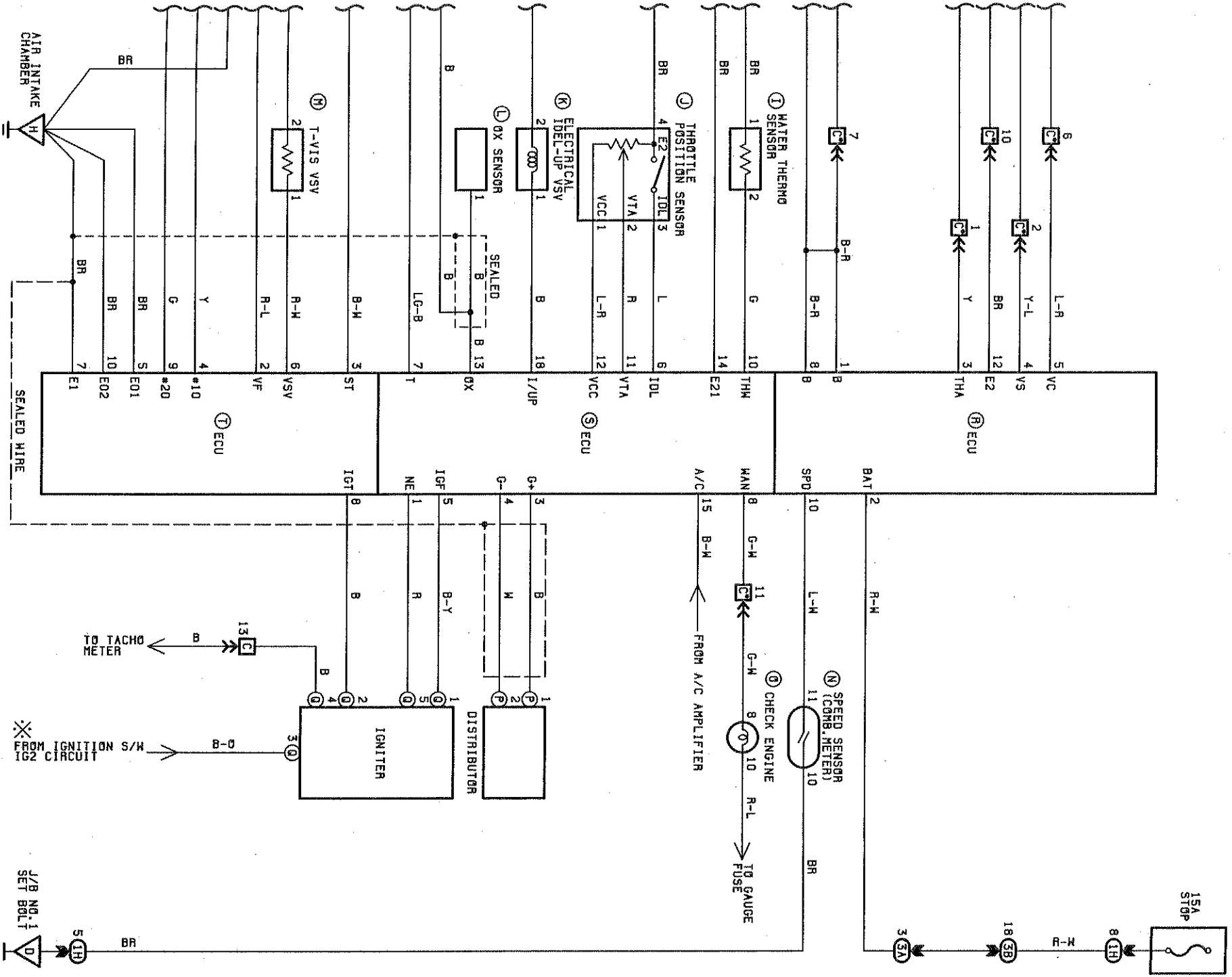

FROM IGNITION S/W  
IG2 CIRCUIT

1/8 NO. 1  
SET BOLT

| EFI MAIN RELAY   | ECU (ELECTRONIC CONTROLLED UNIT)                                   |
|--|--|
| CLOSED WITH IGNITION S/W AT 1G OR ST POSITION            | VOLTAGES AT ECU CONNECTORS   |
| <b>(B) AIR FLOW METER</b>                                | <b>(R) 2-(T) 7: 10-14 VOLTS (ALWAYS)</b>                           |
| 1-2: CLOSED WITH STARTER RUNNING OR MEASURING PLATE OPEN | <b>(R) 1-8-(T) 7: 10-14 VOLTS</b>                                  |
| 3-6: 20-400 Ω (MEASURING PLATE FULLY CLOSED)             | <b>(S) 6-(S) 14: 4-6 VOLTS (THROTTLE VALVE OPEN)</b>               |
| 20-1000 Ω (MEASURING PLATE FULLY OPEN)                   | <b>(S) 11-(S) 14: 0.1-1.0 VOLTS (THROTTLE VALVE FULLY CLOSED)</b>  |
| 3-4: 200-400 Ω   | <b>4-5 VOLTS (THROTTLE VALVE FULLY OPEN)</b>                       |
| 3-7: 10-20 KΩ (-20°C, -4°F)                              | <b>(S) 12-(S) 14: 4-6 VOLTS</b>                                    |
| 4-7 KΩ (0°C, 32°F)                                       | <b>(T) 4-9-(T) 7: 9-14 VOLTS</b>                                   |
| 2-3 KΩ (20°C, 68°F)                                      | <b>(R) 3-(R) 12: 1-3 VOLTS (INTAKE AIR TEMP, 20°C, 68°F)</b>       |
| 0.9-1.3 KΩ (40°C, 104°F)                                 | <b>(S) 10-(S) 14: 0.1-0.5 VOLTS COOLANT TEMP, 90°C, 176°F)</b>     |
| 0.4-0.7 KΩ (60°C, 140°F)                                 | <b>(T) 3-(T) 7: 6-12 VOLTS (IGNITION S/W ST)</b>                   |
| <b>(C) RESISTOR</b>                                      | <b>(T) 8-(T) 7: 0.7-1.0 VOLTS (IDLING)</b>                         |
| 1-2, 1-3: EACH 2.0-3.0 Ω                                 | <b>(S) 8-(T) 7: 0-1.0 VOLTS</b>                                    |
| <b>(D) INJECTOR</b>                                      | <b>10-14 VOLTS (START ENGINE)</b>                                  |
| 1-2: EACH 1.5-3.0 Ω                                      | <b>(S) 15-(T) 7: 10-14 VOLTS (A/C S/W ON)</b>                      |
| <b>(E) CIRCUIT OPENING RELAY</b>                         | <b>0 VOLT (A/C S/W OFF)</b>  |
| CLOSED WITH STARTER RUNNING OR MEASURING PLATE           | <b>(R) 5-(R) 12: 4-9 VOLTS (IGNITION S/W ON)</b>                   |
| (AIR FLOW METER) OPEN                                    | <b>(R) 4-(R) 12: 0.5-2.5 VOLTS (MEASURING PLATE, FULLY CLOSED)</b> |
| <b>(G) STARTER RELAY</b>                                 | <b>5-8 VOLTS (MEASURING PLATE FULLY OPEN)</b>                      |
| 2-4: CLOSED WITH CLUTCH START S/W ON AND                 | <b>2.5-5.5 VOLTS (IDLING)</b>                                      |
| IGNITION S/W AT ST POSITION                              | <b>RESISTANCE AT COMPUTER WIRING CONNECTOR</b>                     |
| (PLEASE REFER TO STARTING AND IGNITION SYSTEMS)          | (DISCONNECT WIRING CONNECTOR)                                      |
| <b>(I) WATER THERMO SENSOR</b>                           | <b>(S) 6-(S) 14: CO Ω (THROTTLE VALVE OPEN)</b>                    |
| 1-2: 10-20 KΩ (-20°C, -4°F)                              | <b>LESS THAN 2.3 KΩ (THROTTLE VALVE FULLY CLOSED)</b>              |
| 4-7 KΩ (0°C, 32°F)                                       | <b>(S) 11-(S) 14: 3.3-10 KΩ (THROTTLE VALVE FULLY OPEN)</b>        |
| 2-3 KΩ (20°C, 68°F)                                      | <b>0.2-0.8 KΩ (THROTTLE VALVE FULLY CLOSED)</b>                    |
| 0.9-1.3 KΩ (40°C, 104°F)                                 |  |
| 0.4-0.7 KΩ (60°C, 140°F)                                 |  |
| 0.2-0.4 KΩ (80°C, 176°F)                                 |  |
| <b>(J) THROTTLE POSITION SENSOR</b>                      |  |
| 2-4: 0.2-0.8 KΩ WITH CLEARANCE BETWEEN LEVER AND         |  |
| STOP SCREEN 0MM (0 IN)                                   |  |
| 3-4: LESS THAN 2.3 KΩ WITH CLEARANCE BETWEEN LEVER AND   |  |
| STOP SCREEN 0.35MM (0.0138 IN)                           |  |
| CO Ω WITH 0.59MM (0.0232 IN)                             |  |
| 2-4: 3.3-10 KΩ WITH THROTTLE VALVE FULLY OPEN            |  |
| 1-4: 3-7 KΩ  |  |

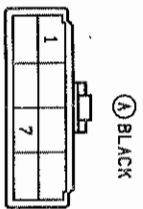

(A) BLACK

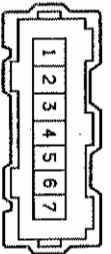

(B) BLACK

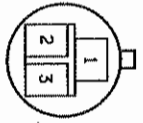

(C) YELLOW

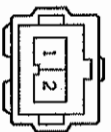

(D) GRAY

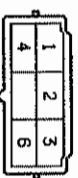

(E) YELLOW

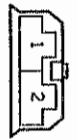

(F) YELLOW



(G)

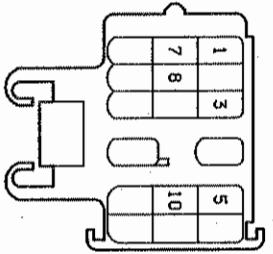

(H)

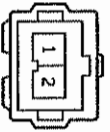

(I) GREEN

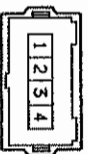

(J) BLACK

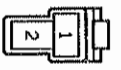

(K) GREEN



(L) YELLOW



(M) BLUE



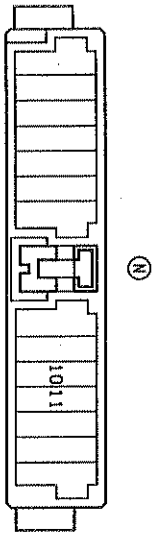

N

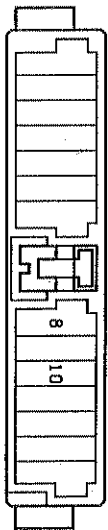

O BLUE

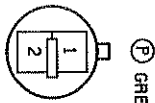

P GREEN

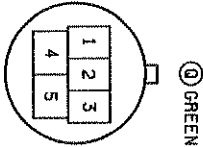

Q GREEN

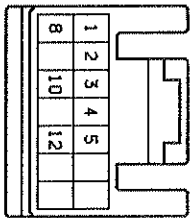

R YELLOW

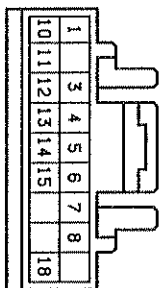

S YELLOW

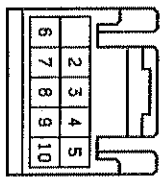

T YELLOW

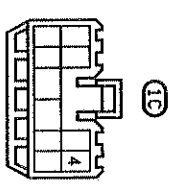

U

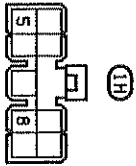

V

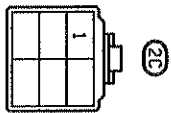

W

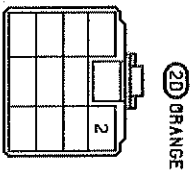

X ORANGE

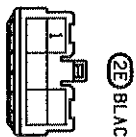

Y BLACK

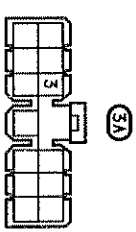

ZA

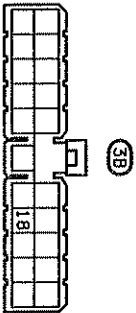

ZB

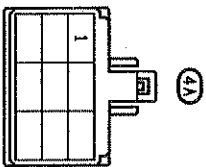

ZC

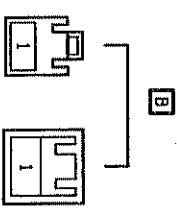

B

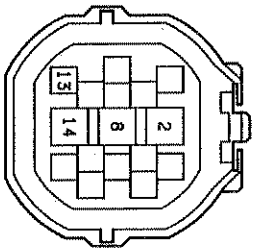

C

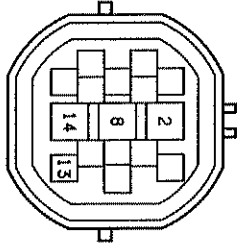

C

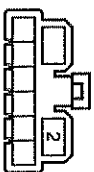

D YELLOW

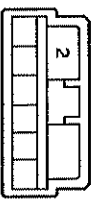

E YELLOW

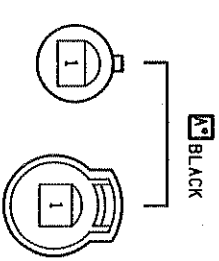

A BLACK

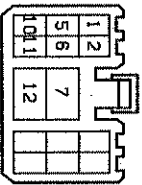

F YELLOW

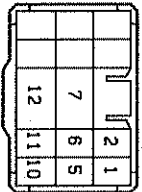

G YELLOW



# EMISSION CONTROL

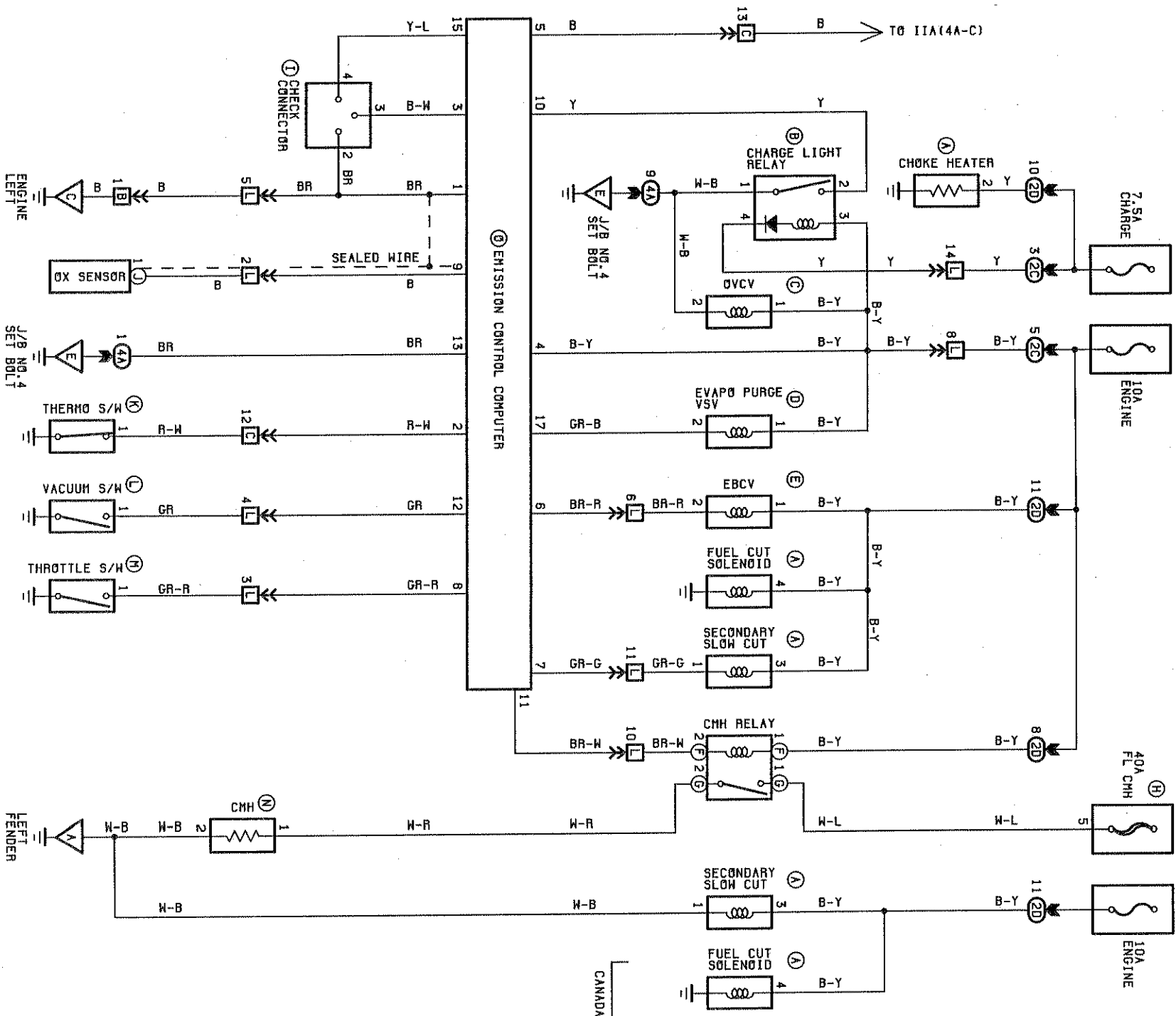

USA

CANADA

CANADA

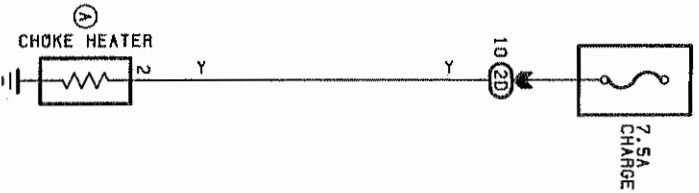

**CHOKE HEATER**  
 2-GROUND: 19-24 Ω

**(B) CHARGE LIGHT RELAY**  
 1-2: OPEN WITH ALTERNATOR CHARGING  
 (4-GROUND: MORE THAN 10 VOLTS)  
 CLOSED WITH ALTERNATOR NOT CHARGING  
 (4-GROUND: LESS THAN 10 VOLTS)

**(C) QVCV (OUTER VENT CONTROL VALVE)**  
 1-2: 41 Ω

**FUEL CUT SOLENOID**  
 4-GROUND: 90 Ω

**SECONDARY SLOW CUT**  
 1-3: 90 Ω

**CMH RELAY**  
 (G) 1 - (G) 2: CLOSED WITH ENGINE RUNNING  
 AND COOLANT TEMP BELOW 43°C (109°F)

**(K) THERMO S/W**  
 1-GROUND: CLOSED BELOW 43°C (109°F)  
 OPEN ABOVE 55°C (131°F)

**(L) VACUUM S/W**  
 1-GROUND: CLOSED ABOVE 95 MMHG (3.74 IN. HG)  
 OPEN BELOW 80 MMHG (3.15 IN. HG)

CANADA

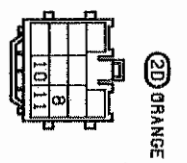
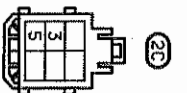
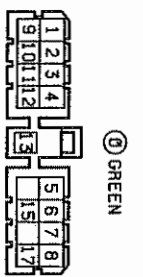
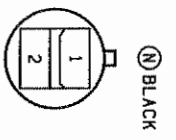
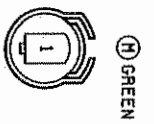
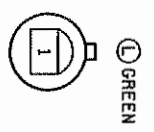
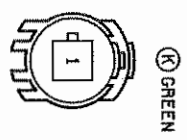
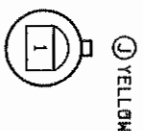
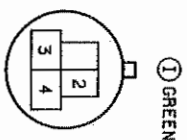
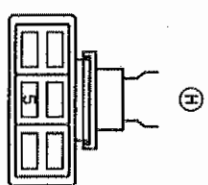
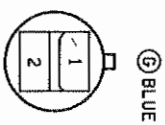
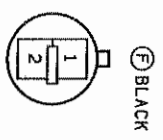
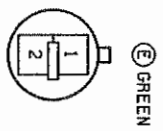
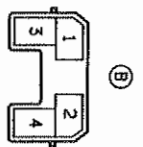
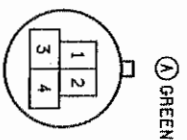

(4A)

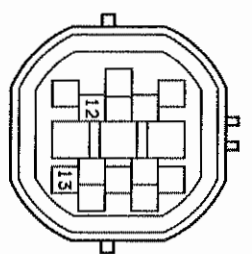
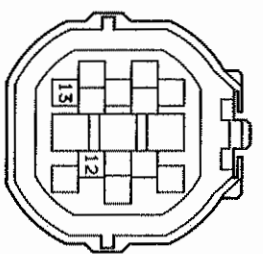
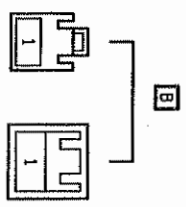
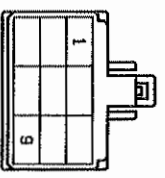

(L)

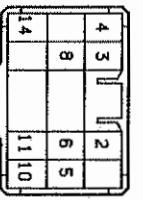
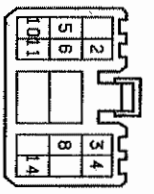

# 6 IDLE-UP

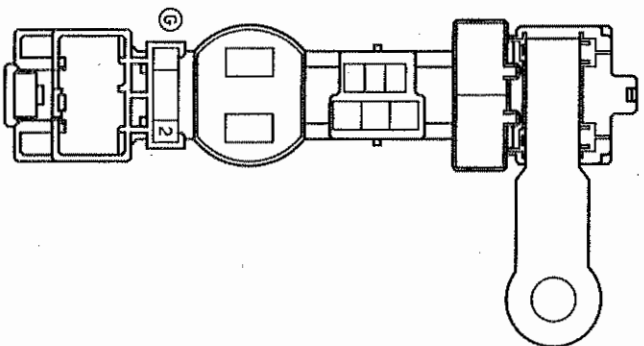
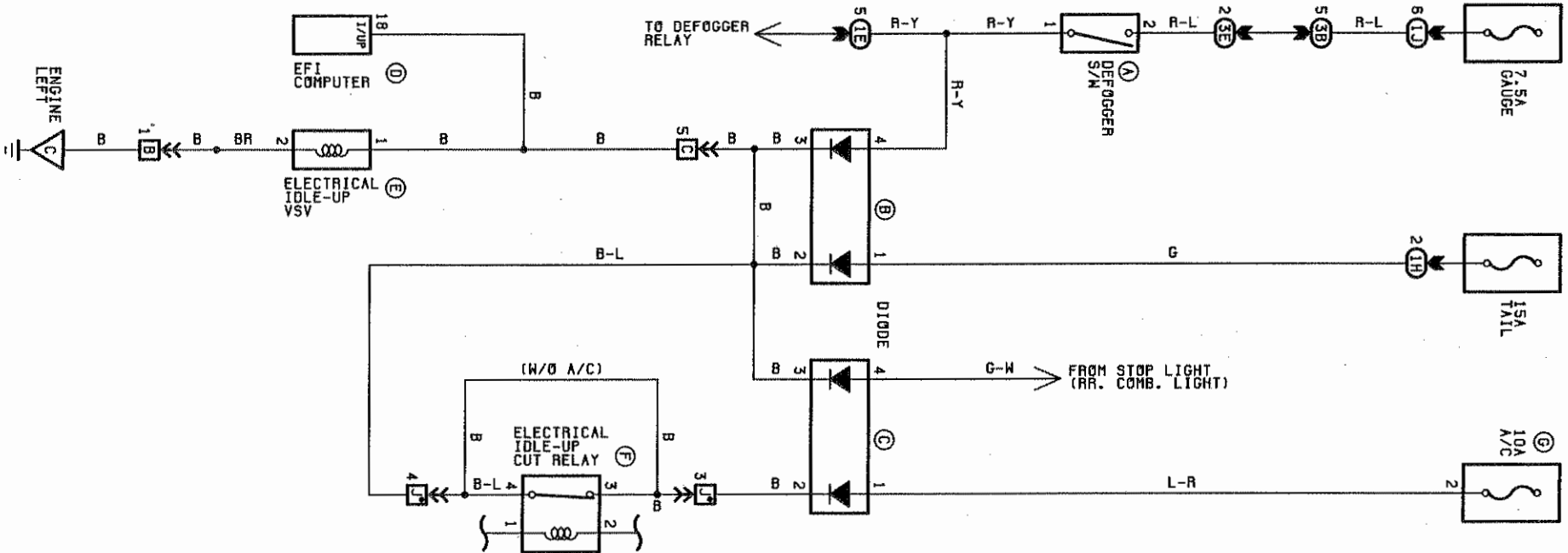

**(E) ELECTRICAL IDLE-UP VSV**  
 1-2 : APPROX 42Ω  
 1-GROUND: 12 VOLTS WITH TAILLIGHTS OR HEADLIGHTS ON,  
 HEATER BLOWER MOTOR ON OR REAR WINDOW DEFOGGER ON

**(F) ELECTRICAL IDLE-UP CUT RELAY**  
 3-4: OPEN WITH IGNITION S/W, A/C S/W AND  
 LOW PRESSURE S/W ON

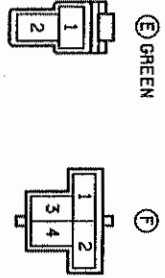
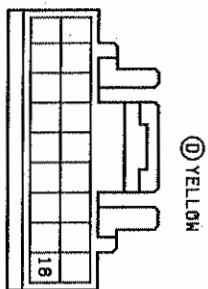
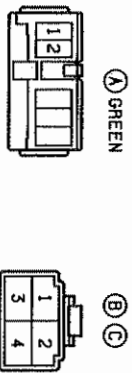

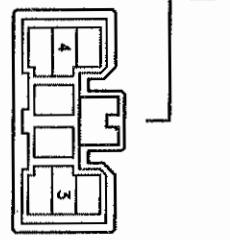
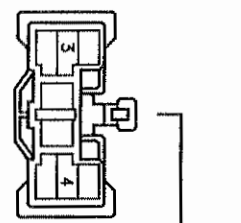
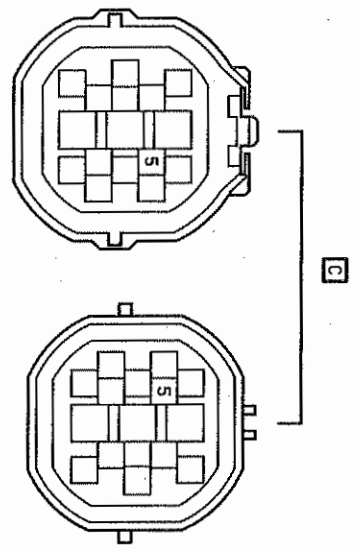
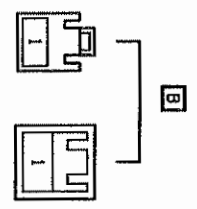
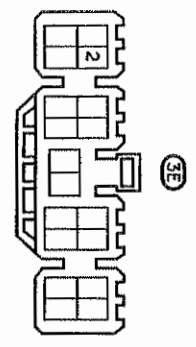
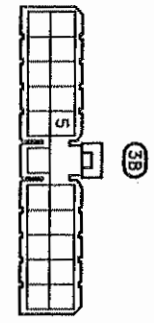
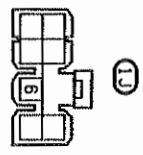
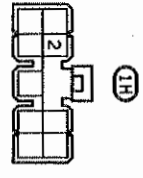
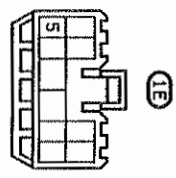

# 7 HEADLIGHTS

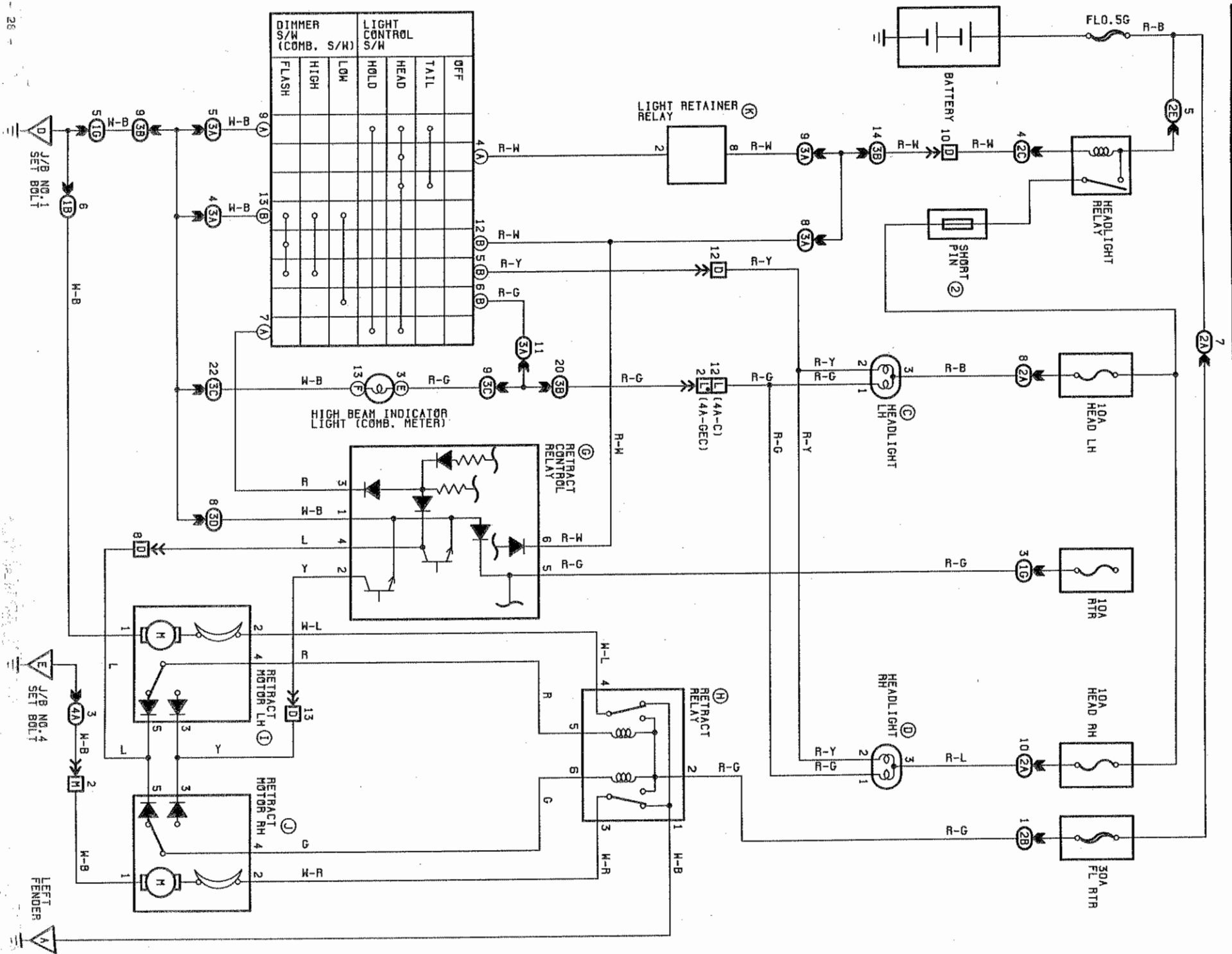

**HEADLIGHT RELAY**

CLOSED WITH LIGHT CONTROL S/W AT HEAD POSITION  
OR DIMMER S/W AT FLASH POSITION

**(G) RETRACT CONTROL RELAY**

5-GROUND: ALWAYS 12 VOLTS

1-GROUND: ALWAYS CONTINUITY  
1-4 : CONTINUITY WITH LIGHT CONTROL S/W AT HEAD POSITION  
OR DIMMER S/W AT FLASH POSITION

1-4 : CONTINUITY FOR 2-4 SECONDS AFTER S/W AT OFF POSITION

1-2 : CONTINUITY FOR 2-4 SECONDS WITH LIGHT CONTROL S/W AT OFF POSITION  
FROM TAIL,HEAD OR HOLD POSITION

1-2 : CONTINUITY BETWEEN TERMINALS FOR 6-14 SECONDS 2-4 SECONDS  
AFTER LIGHT CONTROL S/W OFF

**(H) RETRACT RELAY**

2-4,2-3: CLOSED WITH LIGHT CONTROL S/W AT HEAD POSITION  
UNTIL RETRACT MOTOR AT UP POSITION

2-4,2-3: CLOSED WITH LIGHT CONTROL S/W AT OFF POSITION  
UNTIL RETRACT MOTOR AT DOWN POSITION

2-4,2-3: CLOSED WITH DIMMER S/W AT FLASH POSITION  
UNTIL RETRACT MOTOR AT UP POSITION

2-4,2-3: CLOSED UNLESS DIMMER S/W AT FLASH POSITION  
UNTIL RETRACT MOTOR AT DOWN POSITION

**(I) RETRACT MOTOR**

4-5 : CLOSED UNLESS RETRACT MOTOR AT UP POSITION  
(S/W FOR RETRACT RELAY)

4-3 : CLOSED UNLESS RETRACT MOTOR AT DOWN POSITION  
(S/W FOR RETRACT RELAY)

2-GROUND: 12 VOLTS WITH RETRACT RELAY ON

**(K) LIGHT RETAINER RELAY**

PLEASE REFER TO LIGHT AUTO TURN OFF SYSTEM (SYSTEM NO.13)

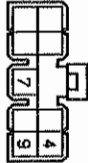

(A)

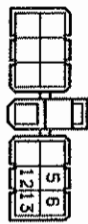

(B) BLACK



(C) (D)

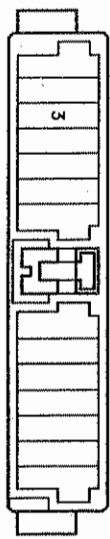

(E) BLUE

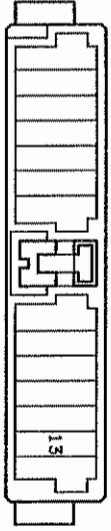

(F)

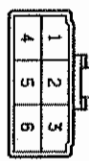

(G) BLUE

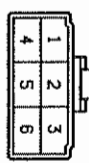

(H)

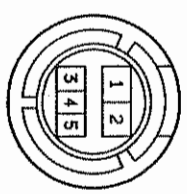

(I) BLACK

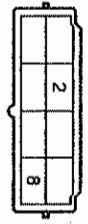

(K)

# 7 HEADLIGHTS

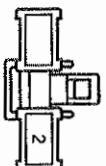
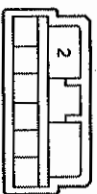
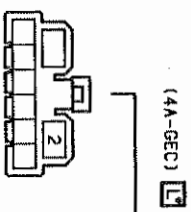
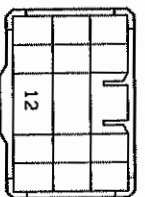
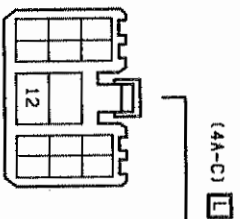
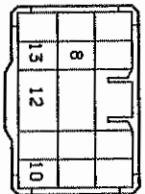
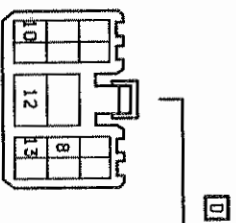
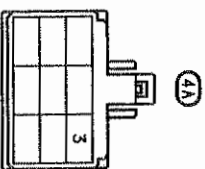
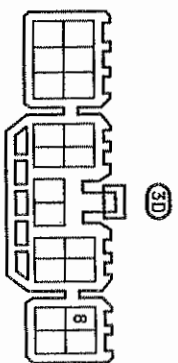
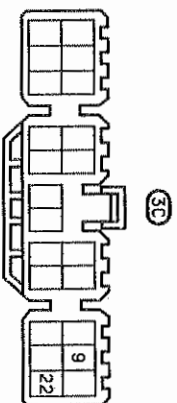
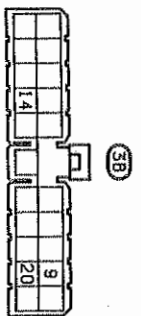
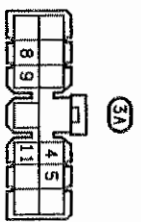
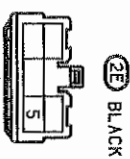
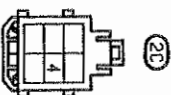
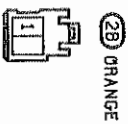
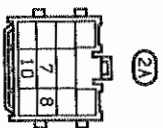
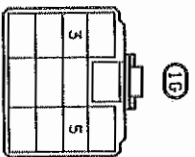
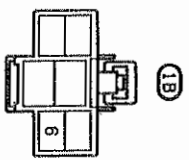

J/B NO. 4 H BROWN

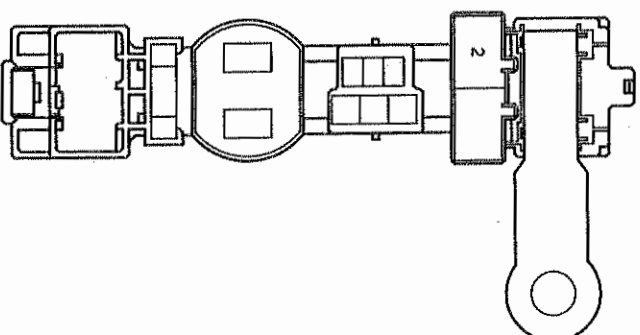



# STOP LIGHTS 8

**① STOP LIGHT S/M**  
1-2: CLOSED WITH BRAKE PEDAL DEPRESSED

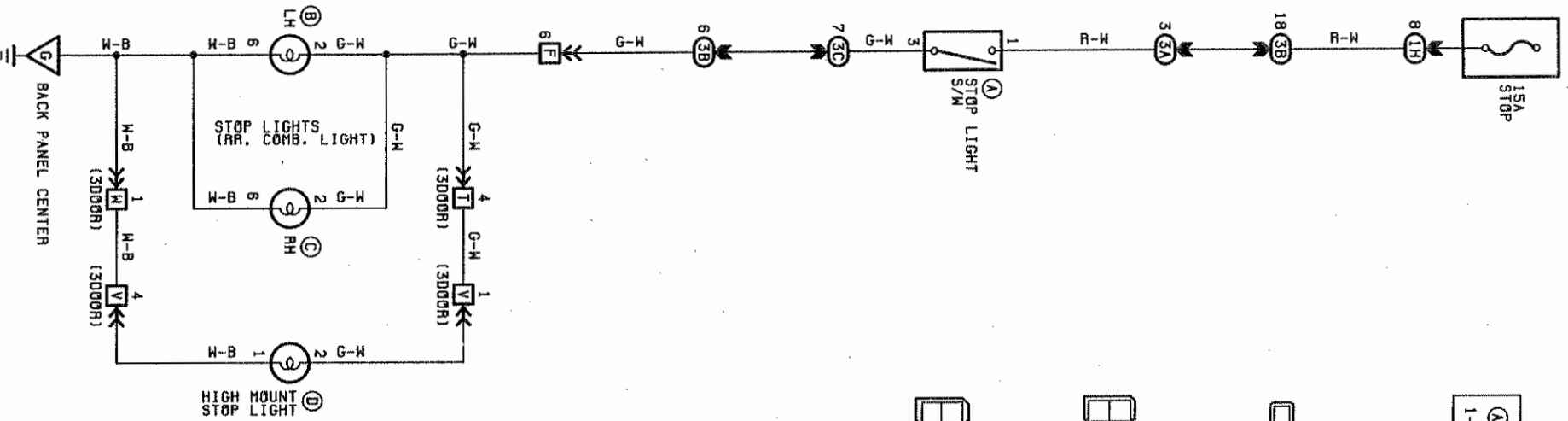
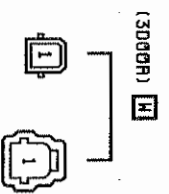
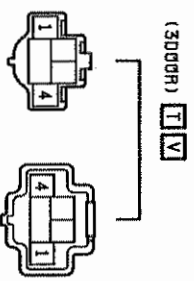
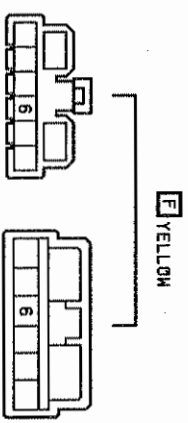
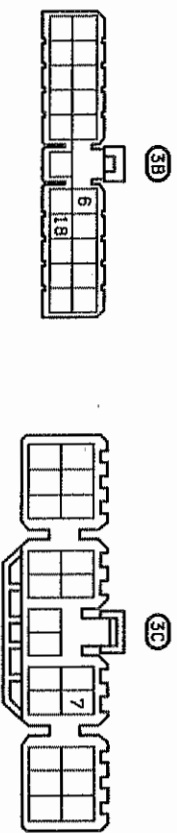
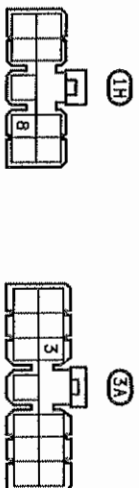
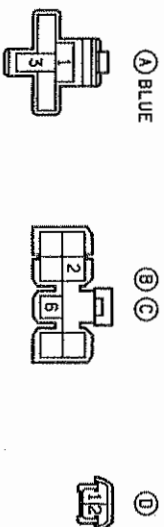

# 9 TAILLIGHTS AND ILLUMINATION

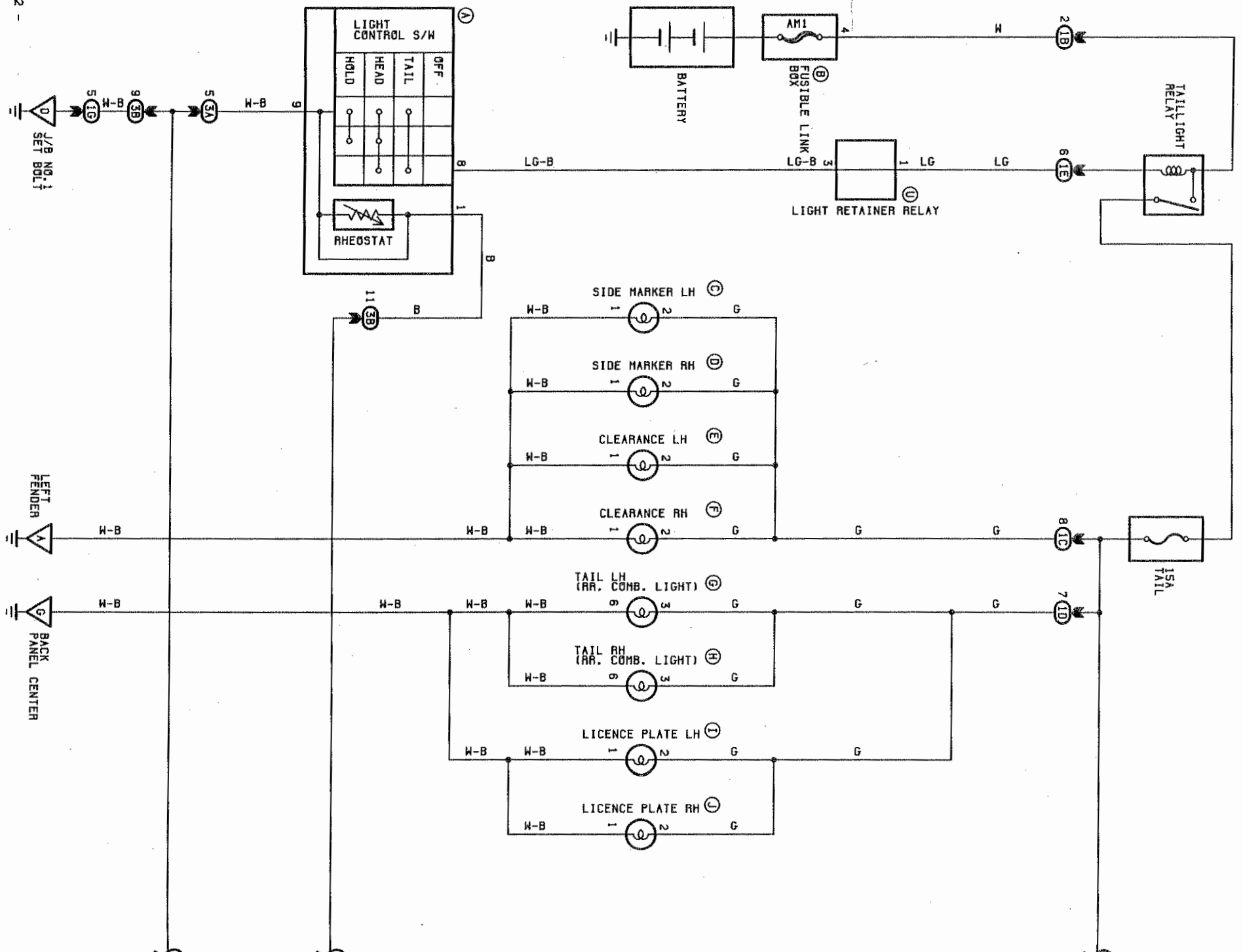

**TAILLIGHT RELAY**  
 CLOSED WITH LIGHT CONTROL S/W AT TAIL OR  
 HEAD POSITION  
 Ⓐ LIGHT CONTROL S/W  
 8-9: CLOSED WITH LIGHT CONTROL S/W AT  
 TAIL OR HEAD POSITION  
 Ⓣ LIGHT RETAINER RELAY  
 PLEASE REFER TO LIGHT AUTO TURN OFF SYSTEM  
 (SYSTEM NO. 13)

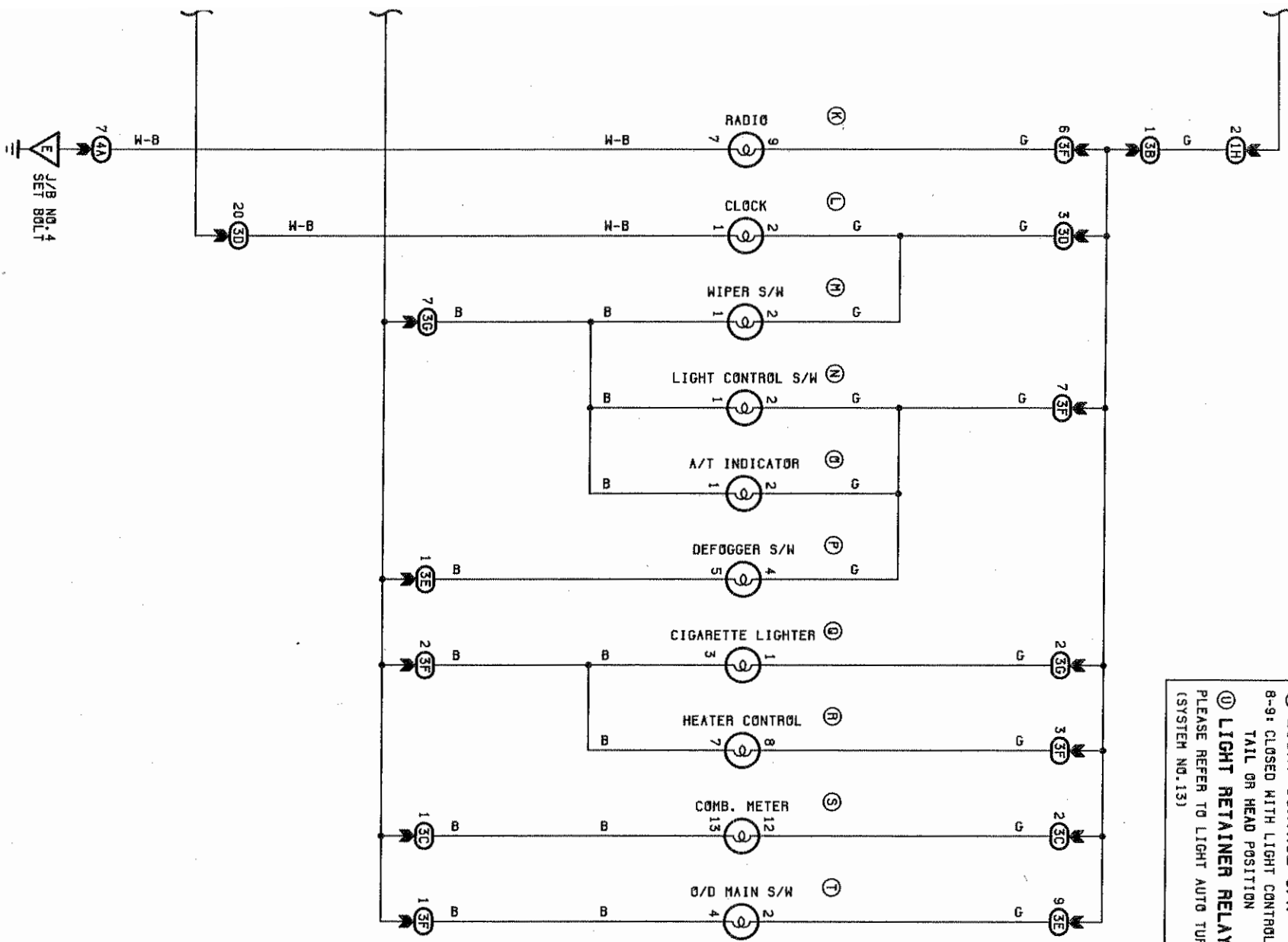



# 9 TAILLIGHTS AND ILLUMINATION

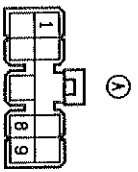

(A)

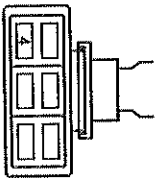

(B)



(C/D)

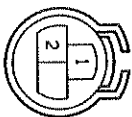

(E/F)



(G/H)



(I/J)

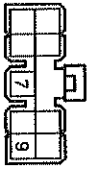

(K) BLUE

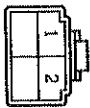

(L)



(M/N)



(O)

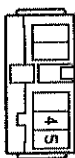

(P) GREEN

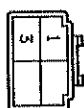

(Q)

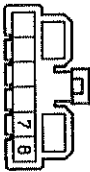

(R)

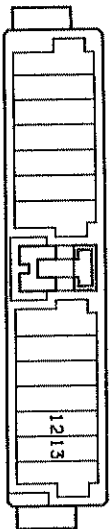

(S) BLUE



(T)

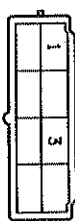

(U)

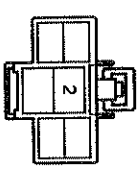

(V) BLACK

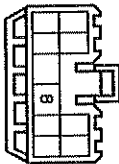

(W)

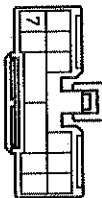

(X)

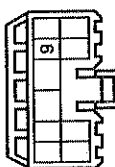

(Y)

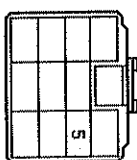

(Z)

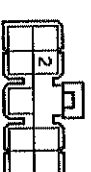

(AA)

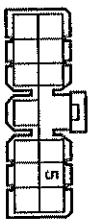

(AB)

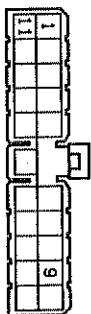

(AC)

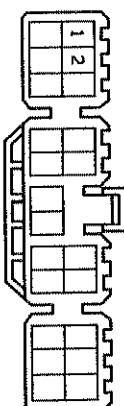

(AD)

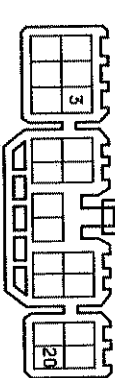

(AE)

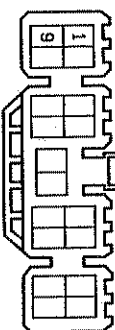

(AF)



(AG)

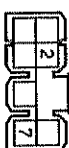

(AH)

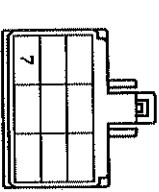

# BACK-UP LIGHTS



**BACK-UP LIGHT S/M**  
CLOSED WITH SHIFT LEVER IN R POSITION

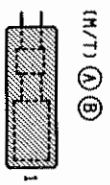

(A/T) (C)

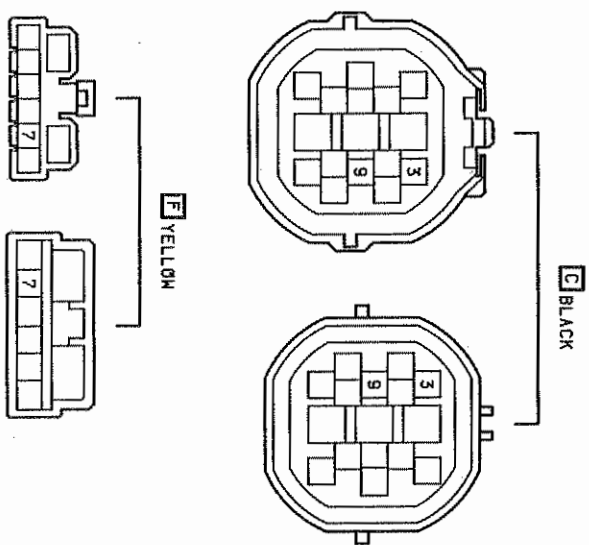
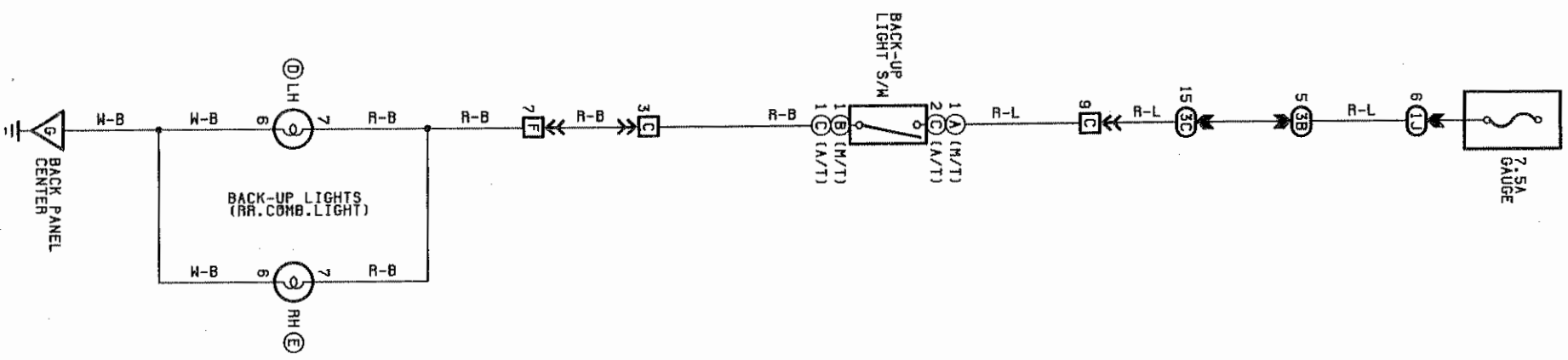
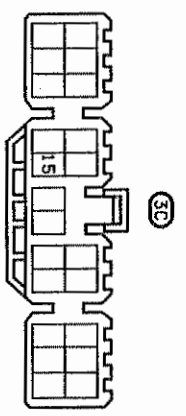
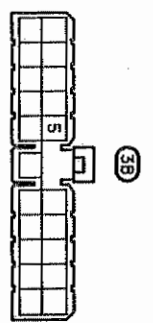
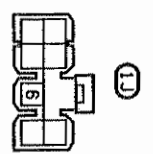
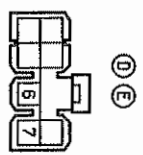
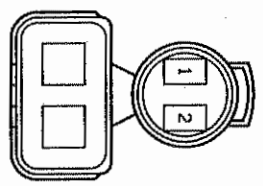



# 11 INTERIOR LIGHTS

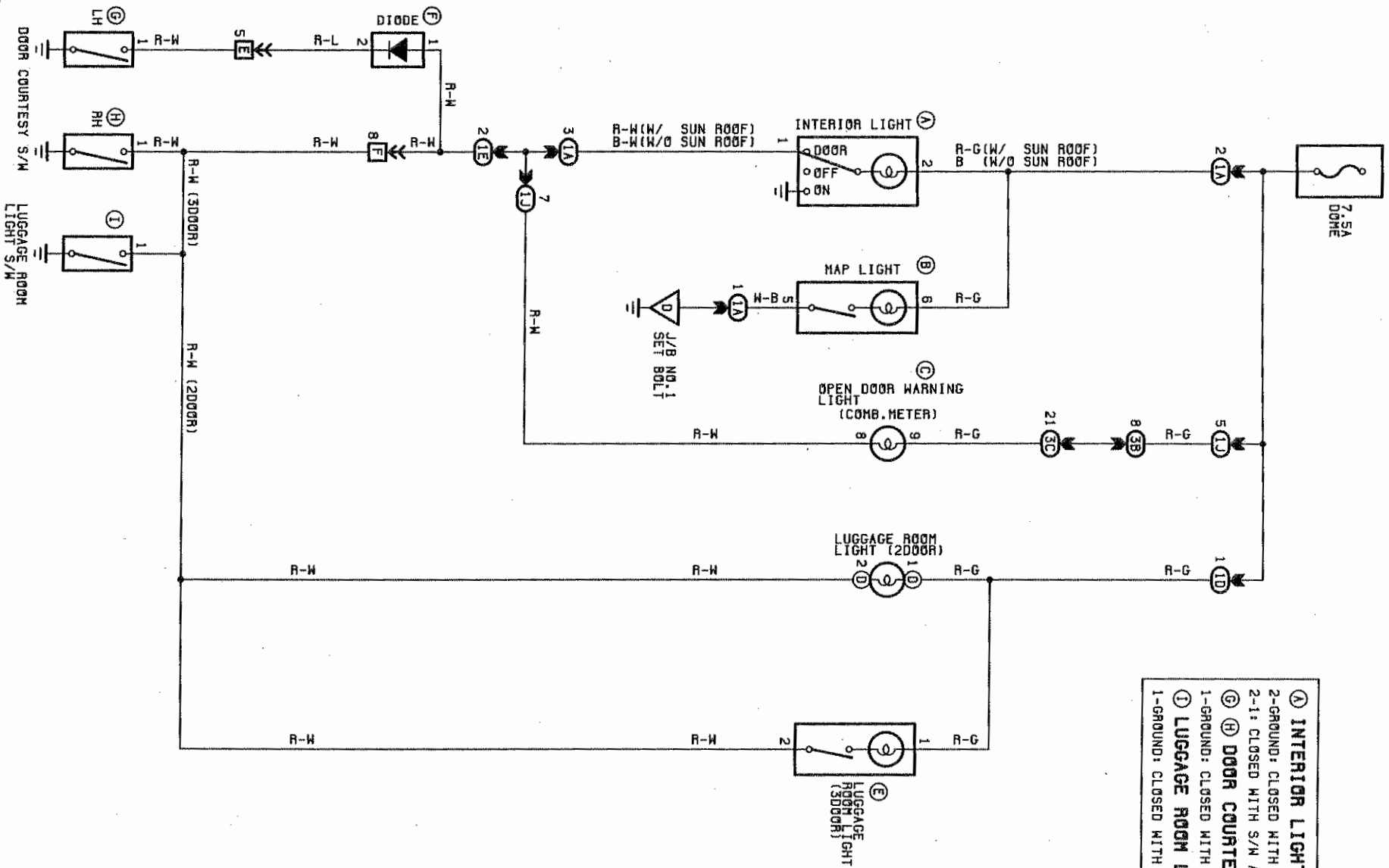

- Ⓐ INTERIOR LIGHT
- 2-GROUND: CLOSED WITH S/M AT ON POSITION
- 2-1: CLOSED WITH S/M AT DOOR POSITION
- Ⓒ DOOR COURTESY S/M
- 1-GROUND: CLOSED WITH DOOR OPEN
- Ⓓ LUGGAGE ROOM LIGHT S/M
- 1-GROUND: CLOSED WITH DOOR OPEN

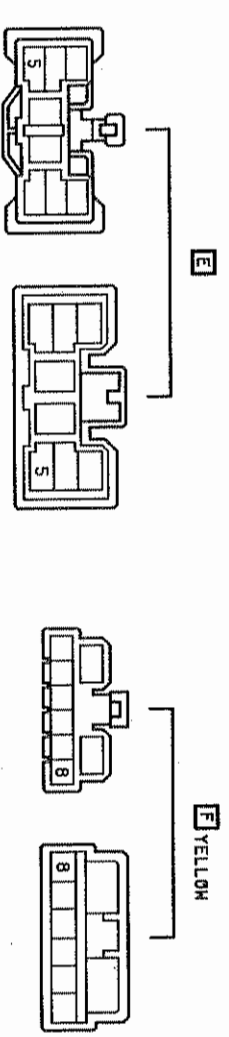
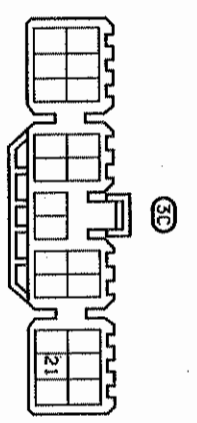
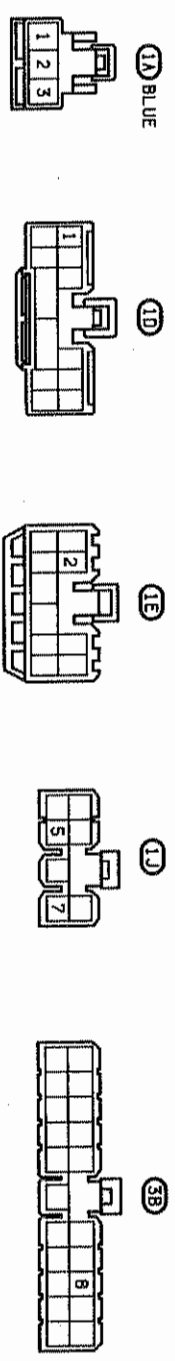
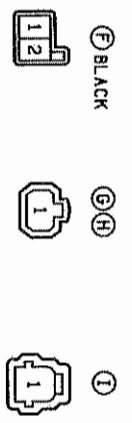
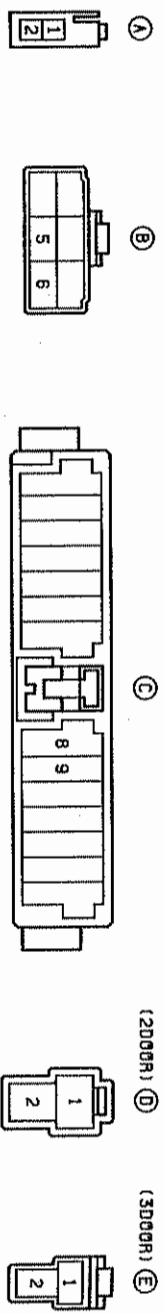



# 12 TURN SIGNAL AND HAZARD WARNING LIGHTS

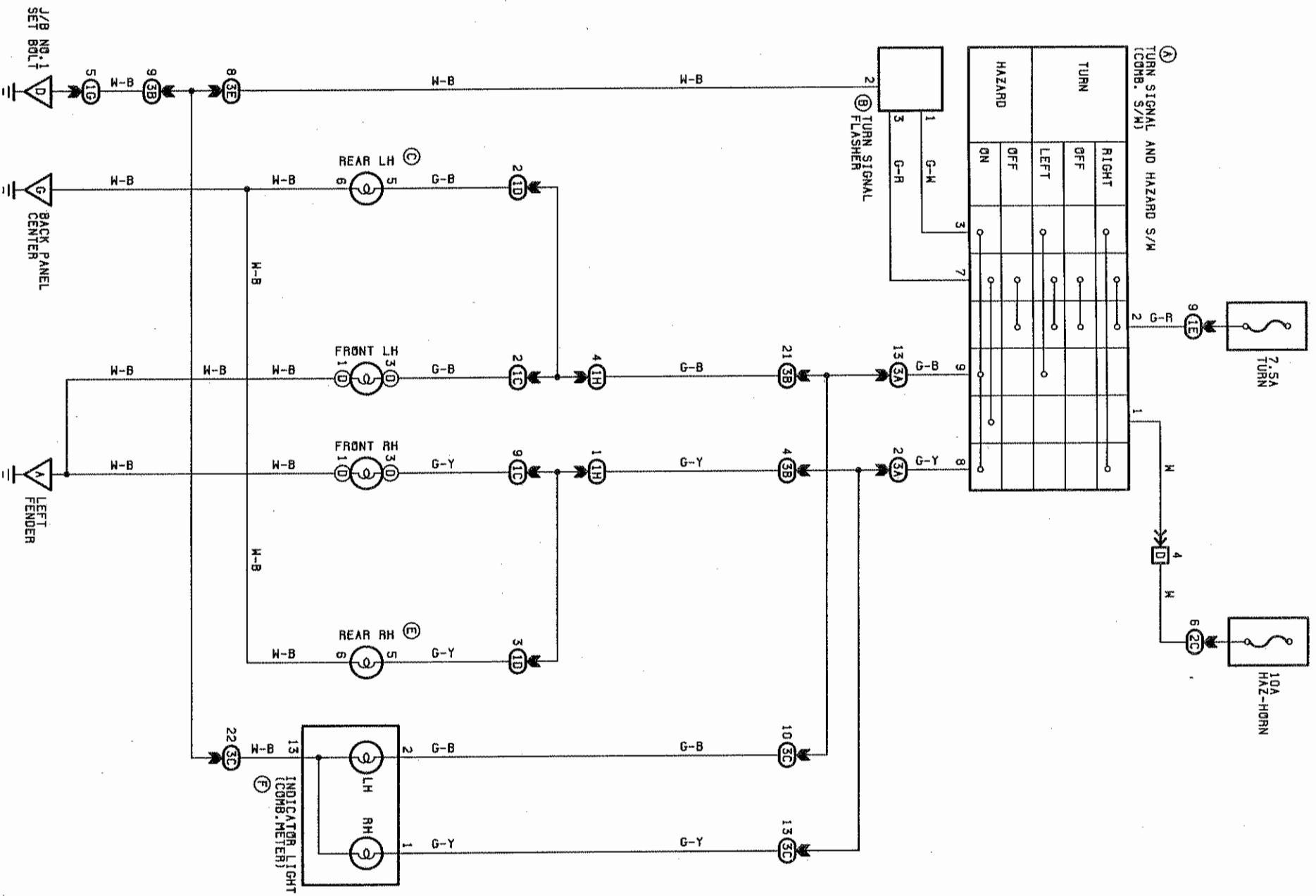



**(A) TURN SIGNAL AND HAZARD S/M**  
 1-GROUND: ALWAYS 12 VOLTS  
 2-GROUND: 12 VOLTS WITH IGNITION S/M ON

**(B) TURN SIGNAL FLASHER**  
 3-GROUND: 12 VOLTS WITH IGNITION S/M ON OR HAZARD S/M ON  
 1-GROUND: CHANGES FROM 12 TO 0 VOLTS WITH IGNITION S/M ON AND TURN SIGNAL S/M LEFT OR RIGHT, OR WITH HAZARD S/M ON

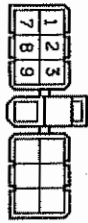

(A) BLACK

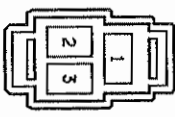

(B)

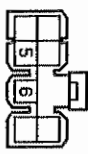

(C) (E)

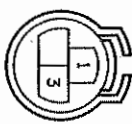

(D)

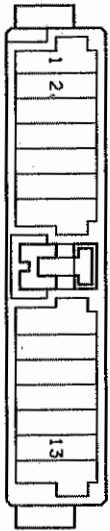

(E)

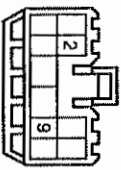

(1C)

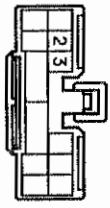

(1D)

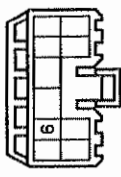

(1E)

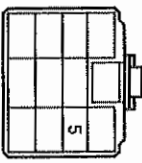

(1G)

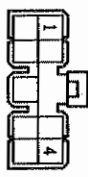

(1H)

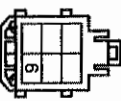

(2C)

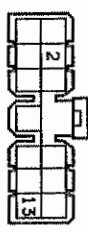

(3A)

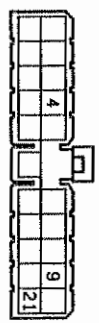

(3B)

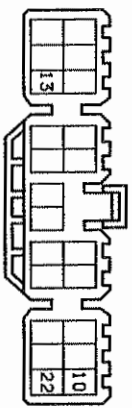

(3C)

(3E)

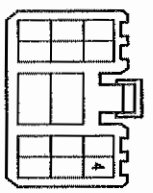
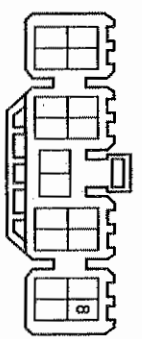

(D)

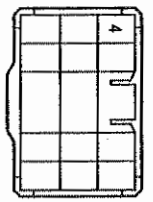

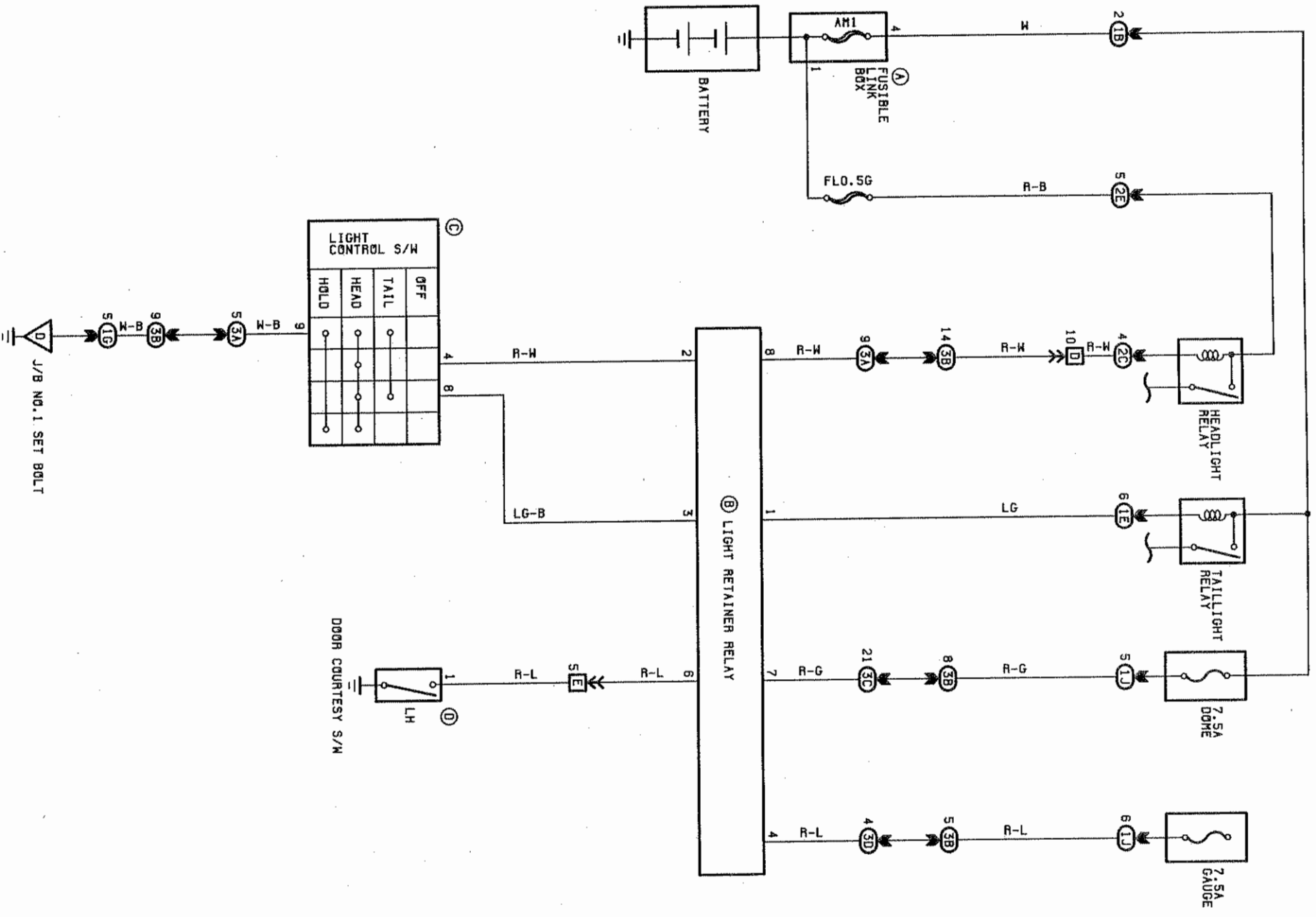

J/B NO. 1 SET BOLT

**ⓑ LIGHT RETAINER RELAY**

2-GROUND, 3-GROUND: APPROX. 12 VOLTS WITH LIGHT CONTROL S/W OFF  
 (HEADLIGHT, TAILLIGHT OFF)  
 : 0 VOLT WITH LIGHT CONTROL S/W A/T HEAD POSITION(TAILLIGHTS ON)  
 (HEADLIGHTS ON)  
 : 0 VOLT WITH LIGHT CONTROL S/W A/T TAIL POSITION(TAILLIGHTS ON)  
 2-GROUND, 3-GROUND: 0 VOLT WITH LIGHT CONTROL S/W A/T HEAD, TAIL POSITION AFTER  
 IGNITION S/W TURNED OFF AND LH DOOR OPEN  
 (HEADLIGHT, TAILLIGHT OFF)  
 (HEADLIGHT, TAILLIGHT TURN OFF AUTOMATICALLY WHEN THE IGNITION S/W  
 IS TURNED OFF AND LH DOOR OPEN)

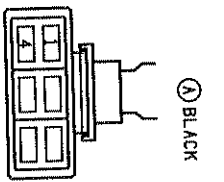

ⓐ BLACK

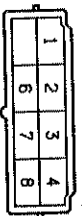

ⓑ



ⓒ



ⓓ

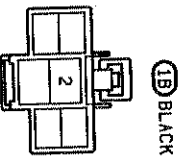

1B BLACK

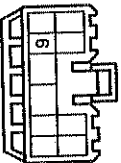

1E

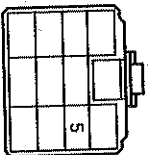

1G



1J

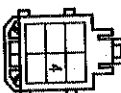

2C

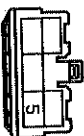

2E BLACK

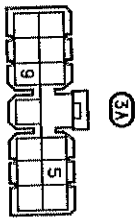

3A

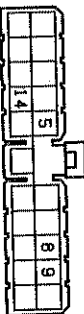

3B

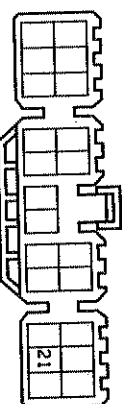

3C

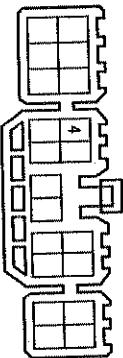

3D



E

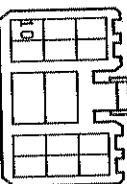
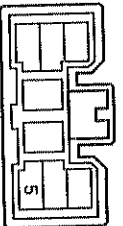

D

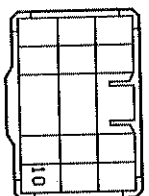

# FRONT WIPERS AND WASHER

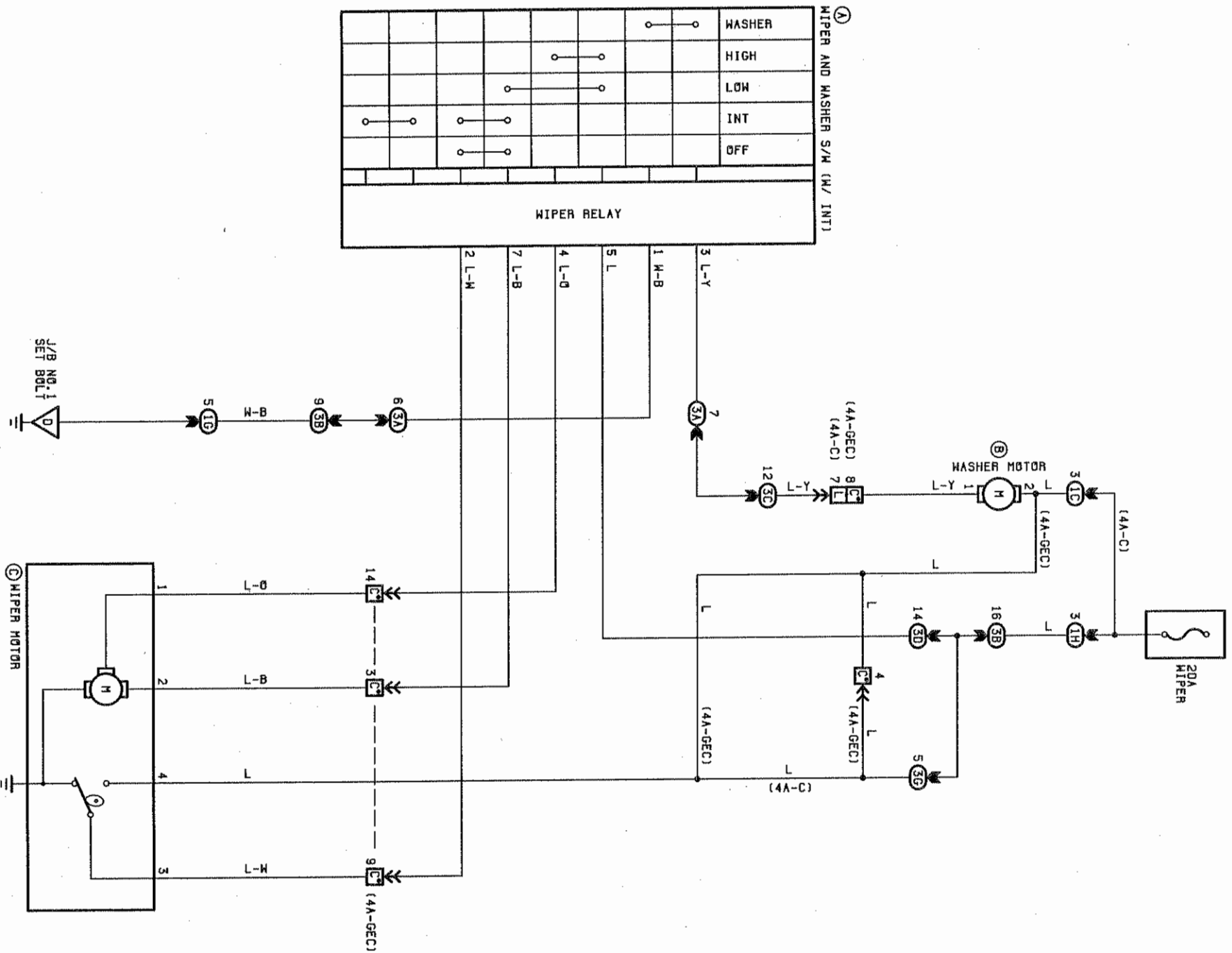

**(A) WIPER AND WASHER S/W**  
 5-GROUND: 12 VOLTS WITH IGNITION S/W ON  
 7-GROUND: 12 VOLTS EVERY 4 SECONDS INTERMITTENTLY  
 WITH WIPER S/W AT INT POSITION  
 2-GROUND: 12 VOLTS WITH IGNITION S/W ON UNLESS WIPER  
 MOTOR AT STOP POSITION  
 7-GROUND: 12 VOLTS WITH IGNITION S/W ON AND AFTER  
 WIPER S/W OFF UNTIL WIPER MOTOR STOPS  
**(C) WIPER MOTOR**  
 3-4: CLOSED UNLESS WIPER MOTOR AT STOP POSITION

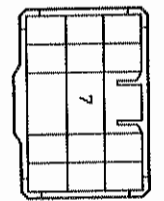
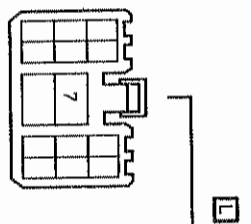
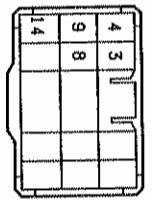
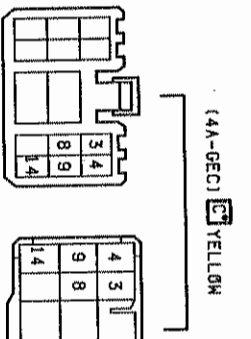
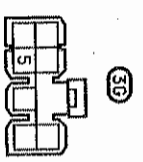
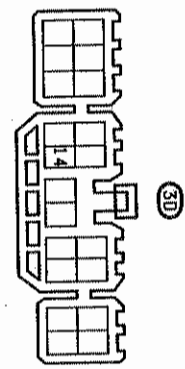
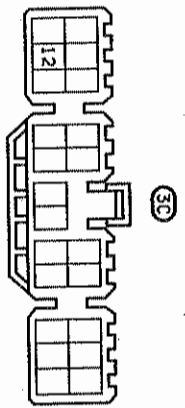
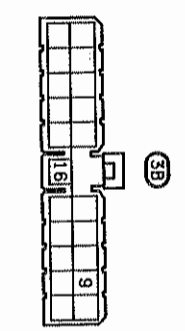
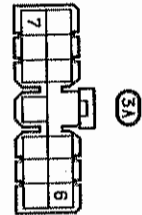
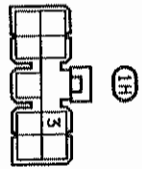
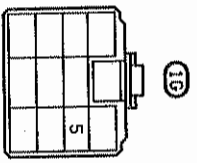
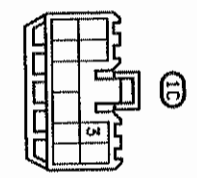
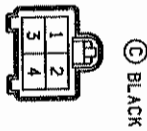
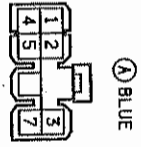

# 15 REAR WIPER AND WASHER

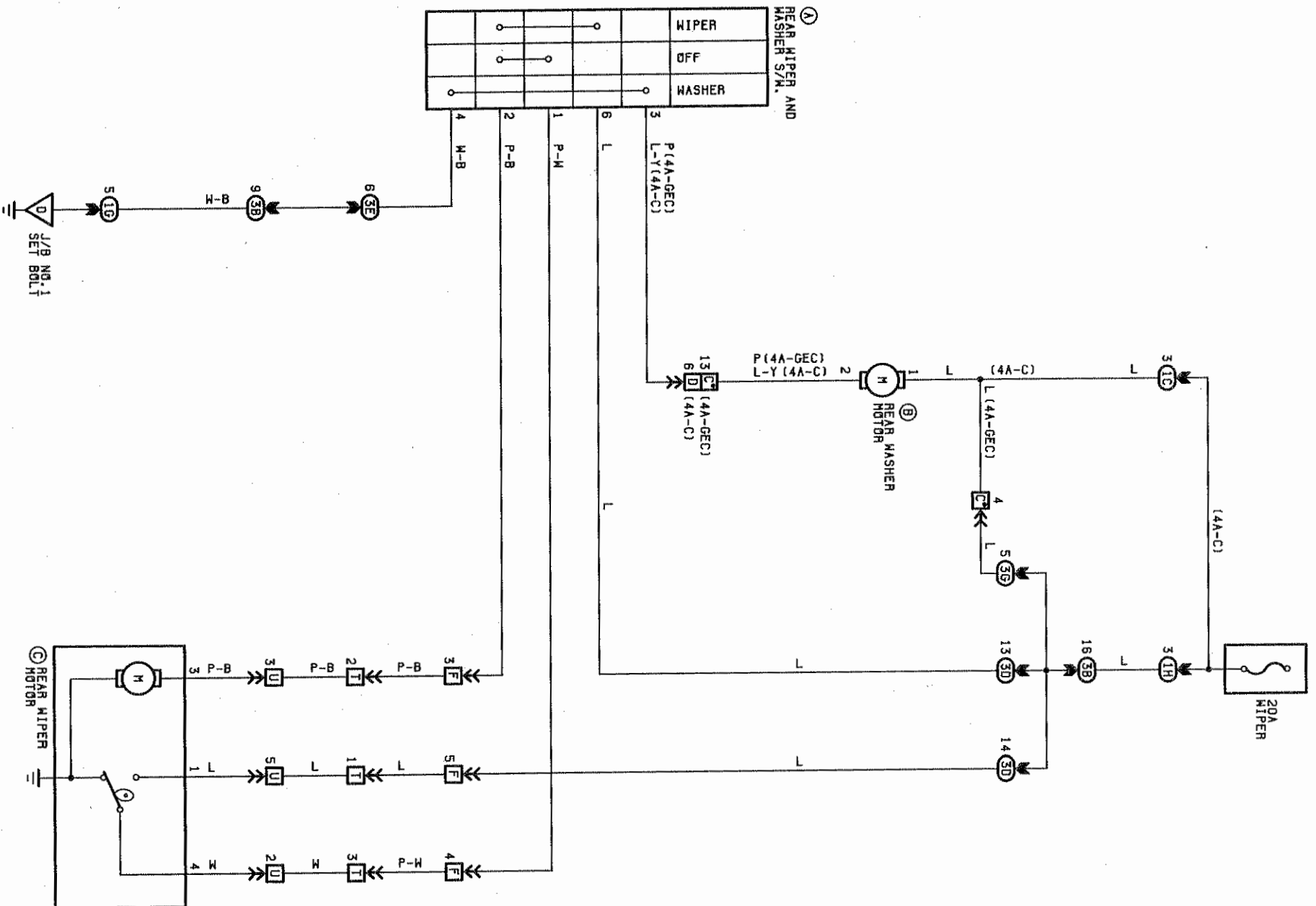

**C REAR WIPER MOTOR**  
1-4: CLOSED UNLESS REAR WIPER MOTOR AT STOP POSITION

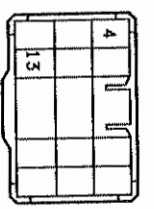
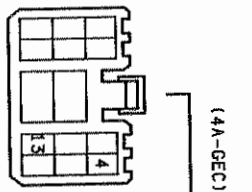
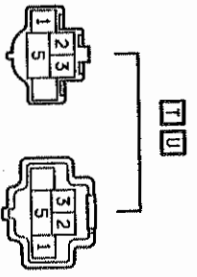
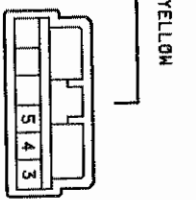
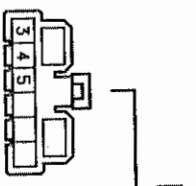
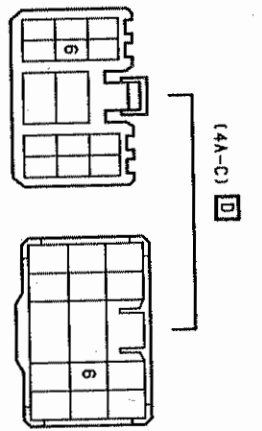
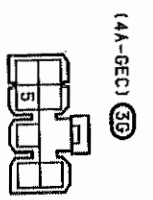
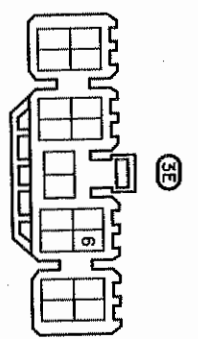
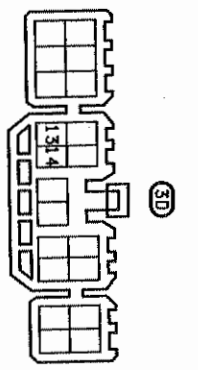
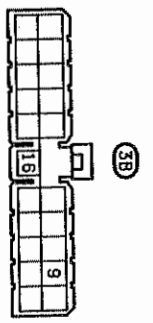
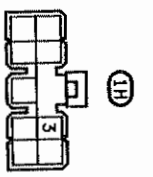
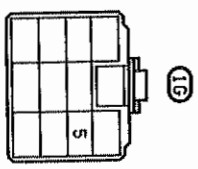
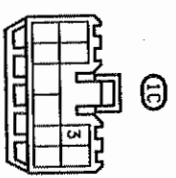
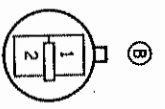
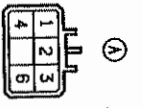

**(A) O/D RELAY**  
 1-2: OPEN WITH IGNITION S/W ON AND WATER THERMO S/W CLOSED  
 2-4: APPROX. 71 Ω  
**(C) O/D MAIN S/W**  
 1-4: CLOSED WITH O/D S/W ON  
 OPEN WITH O/D S/W OFF  
**(D) O/D SOLENOID**  
 1-GROUND: APPROX. 13 Ω  
**(E) WATER THERMO S/W**  
 1-GROUND: CLOSED BELOW 43°C (109° F)  
 OPEN ABOVE 55°C (131° F)

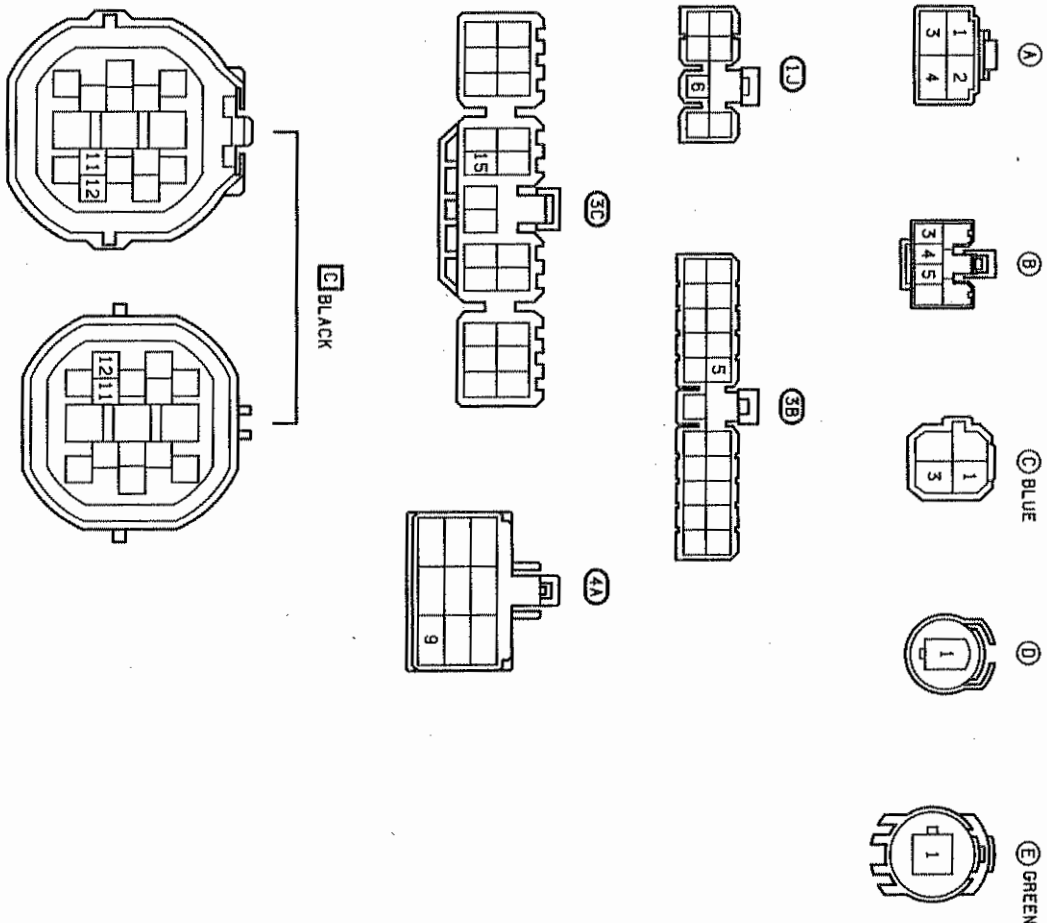
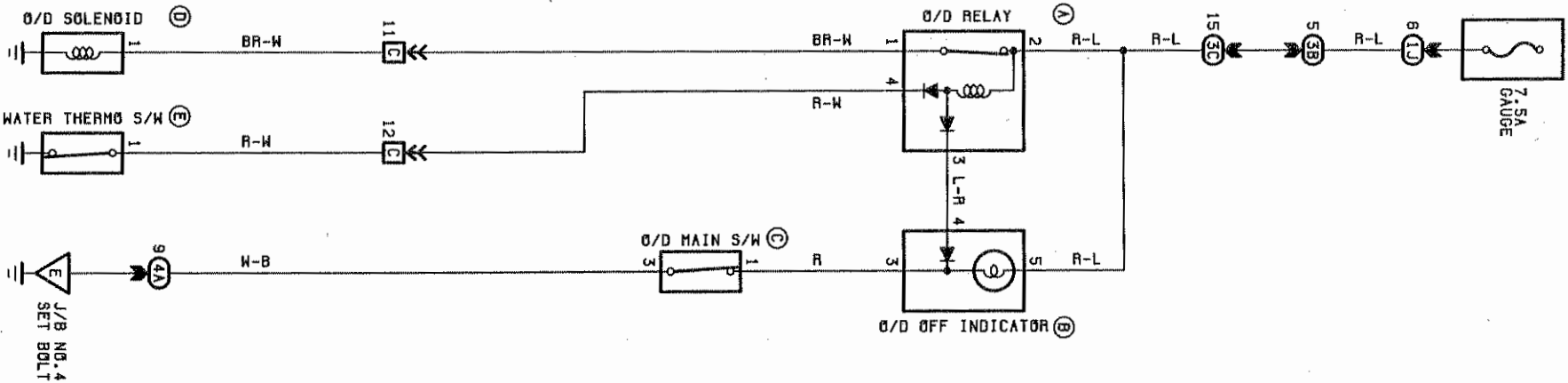



# SEAT BELT WARNING 17



**Ⓒ SEAT BELT WARNING RELAY**  
 2-GROUND: 12 VOLTS WITH IGNITION S/W AT 1G POSITION  
 (POWER AND SIGNAL OF BELT WARNING BUZZER FOR 4-8 SECONDS)  
 5-GROUND: 0 VOLT FOR 4-8 SECONDS WITH IGNITION S/W ON AND  
 12 VOLTS THEREAFTER  
 6-GROUND: CONTINUITY UNLESS DRIVER'S LAP BELT IN USE  
 (SIGNAL OF BELT WARNING BUZZER)  
**Ⓓ BUCKLE S/W**  
 1-2: OPEN WITH DRIVER'S LAP BELT IN USE

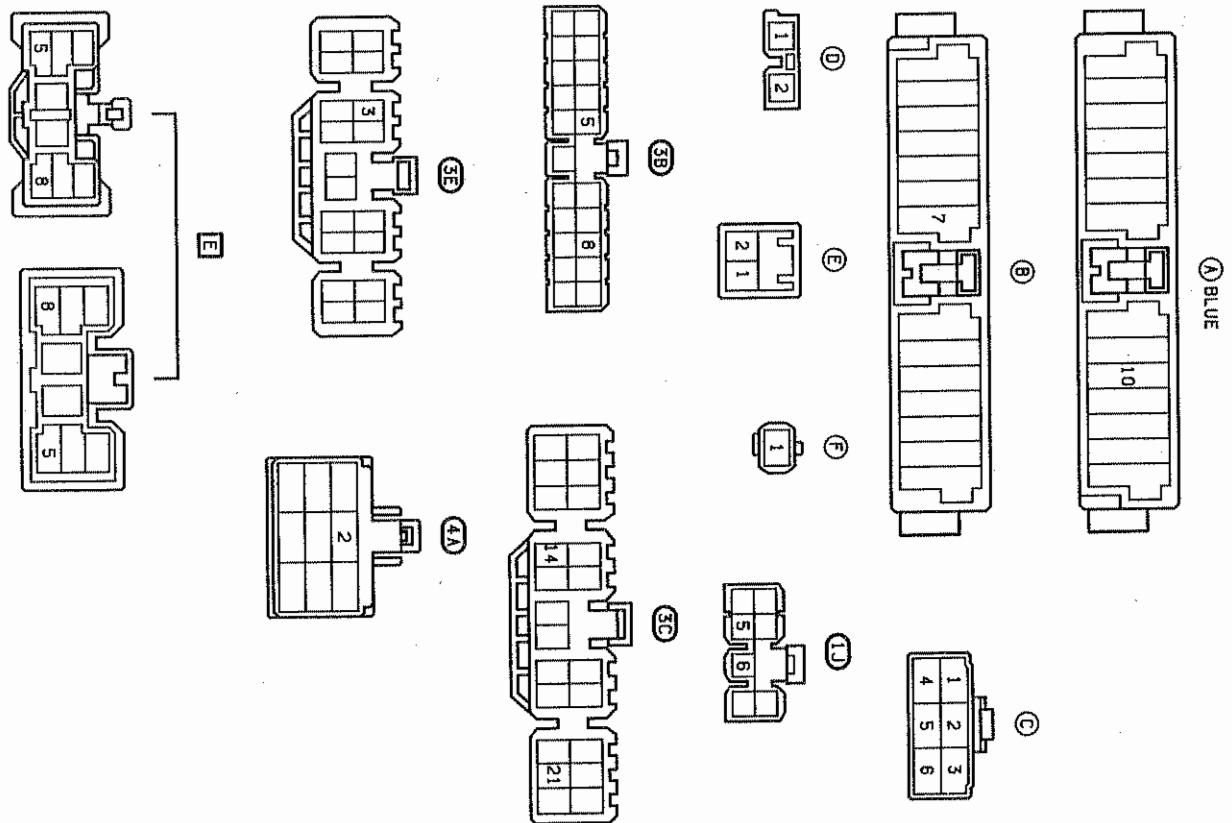
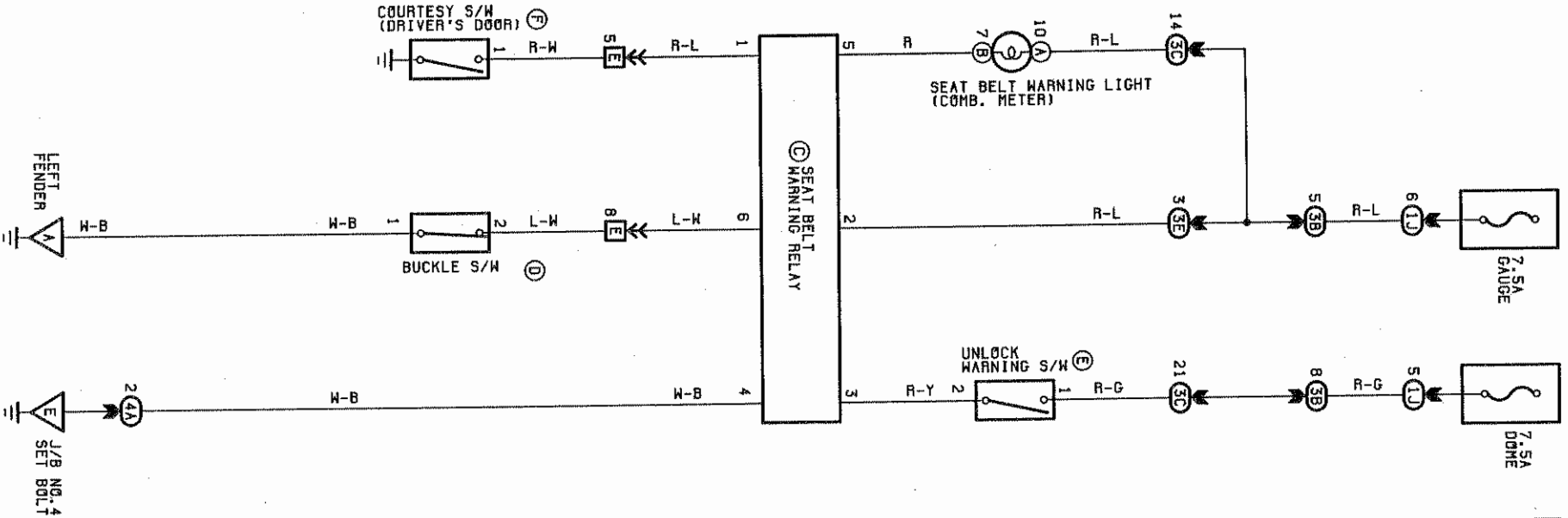

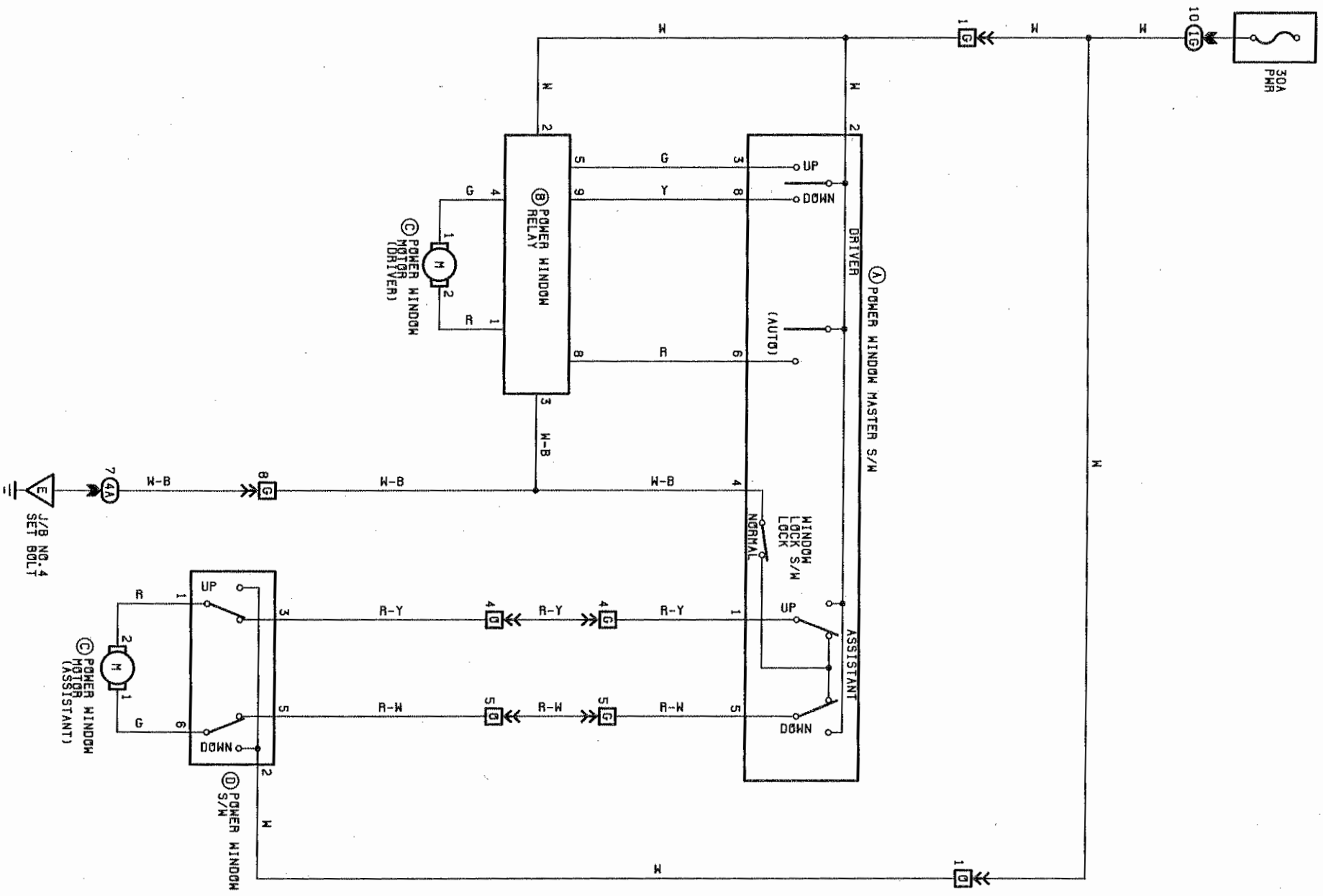

**(A) POWER WINDOW MASTER S/W**

2-GROUND: 12 VOLTS WITH IGNITION S/W AT IG OR ST POSITION  
 4-GROUND: ALWAYS CONTINUITY

**(B) POWER WINDOW RELAY**

2-GROUND: 12 VOLTS WITH IGNITION S/W AT IG OR ST POSITION  
 3-GROUND: ALWAYS CONTINUITY  
 5-GROUND: 12 VOLTS WITH IGNITION S/W AT IG OR ST POSITION AND MASTER S/W (DRIVER'S WINDOW) AT UP POSITION  
 8-GROUND: 12 VOLTS WITH IGNITION S/W AT IG OR ST POSITION AND MASTER S/W (DRIVER'S WINDOW) AT DOWN AUTO POSITION  
 9-GROUND: 12 VOLTS WITH IGNITION S/W AT IG OR ST POSITION AND MASTER S/W (DRIVER'S WINDOW) AT DOWN

**WINDOW LOCK S/W**

OPEN WITH WINDOW LOCK S/W AT LOCK POSITION

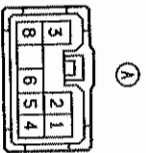

(A)

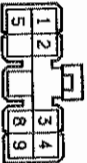

(B)

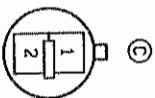

(C)

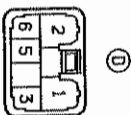

(D)

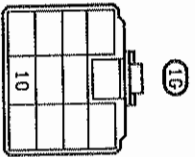

(10G)

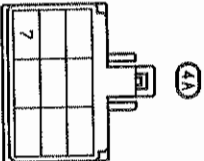

(4A)

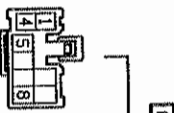

(G)

(D)

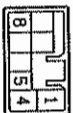

# 19 REAR WINDOW DEFOGGER

**(A) FUSIBLE LINK BOX**  
 AH1:60A (4A-C), 80A (4A-GEC)  
**DEFOGGER RELAY**  
 CLOSED WITH IGNITION S/W AT IG POSITION  
 AND DEFOGGER S/W GN  
**DEFOG CB**  
 OPEN ABOVE 30 A

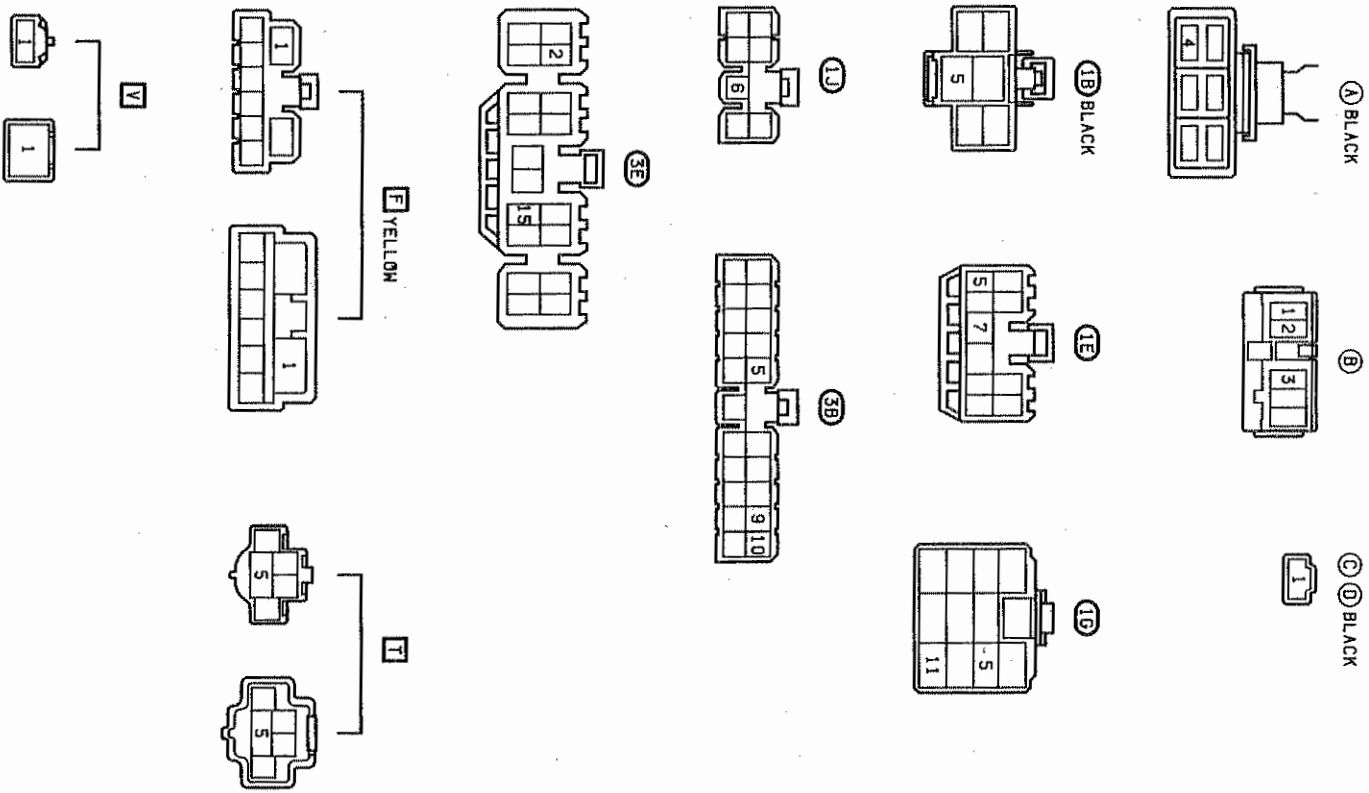
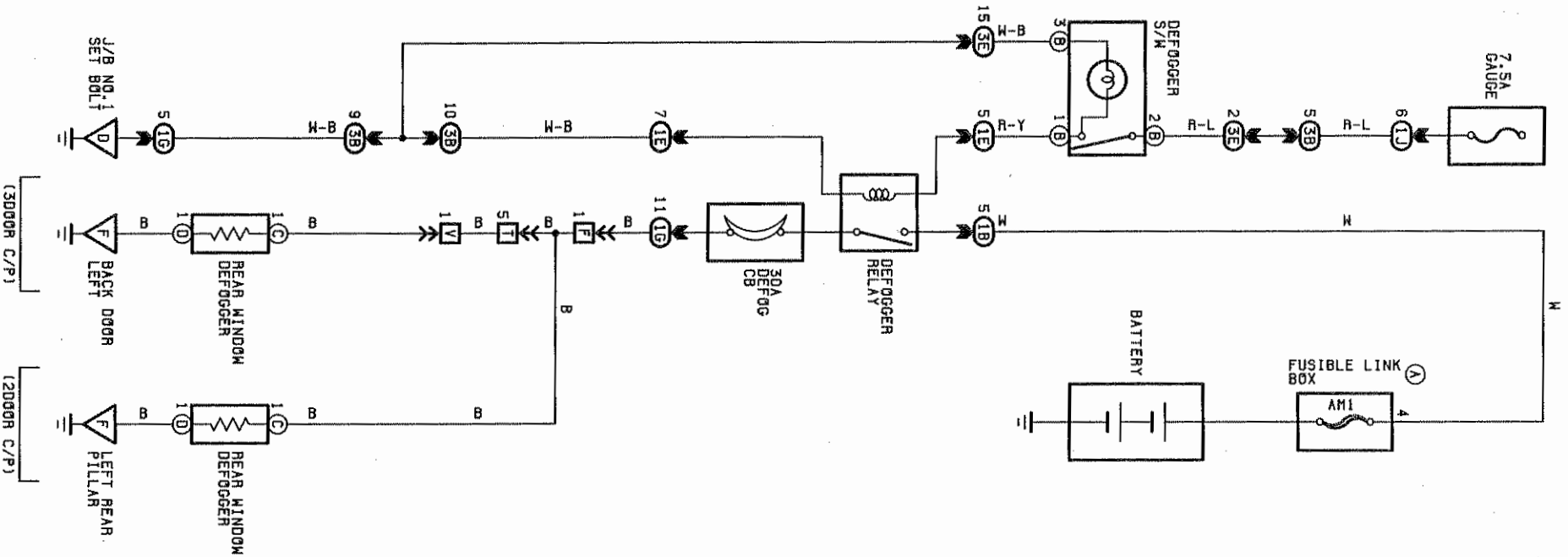

# REMOTE CONTROL MIRRORS



- (A) REMOTE CONTROL MIRROR S/W**  
 1-GROUND: 12 VOLTS WITH IGNITION S/W AT ACC OR IG POSITION  
 3-2 : CONTINUITY WITH OPERATION S/W AT UP OR LEFT POSITION  
 1-3 : CONTINUITY WITH OPERATION S/W AT DOWN OR RIGHT POSITION

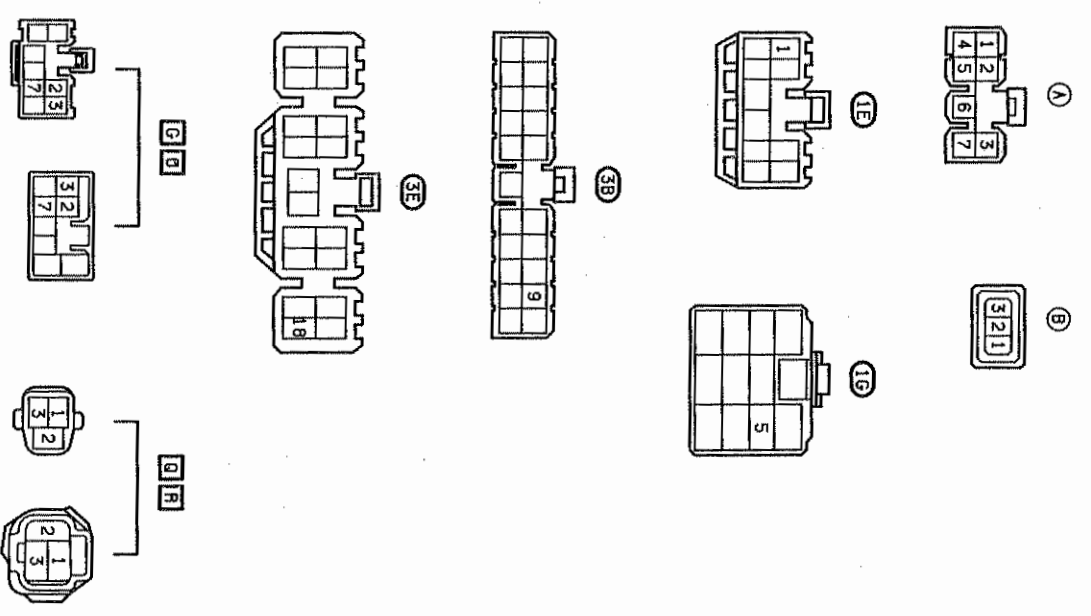
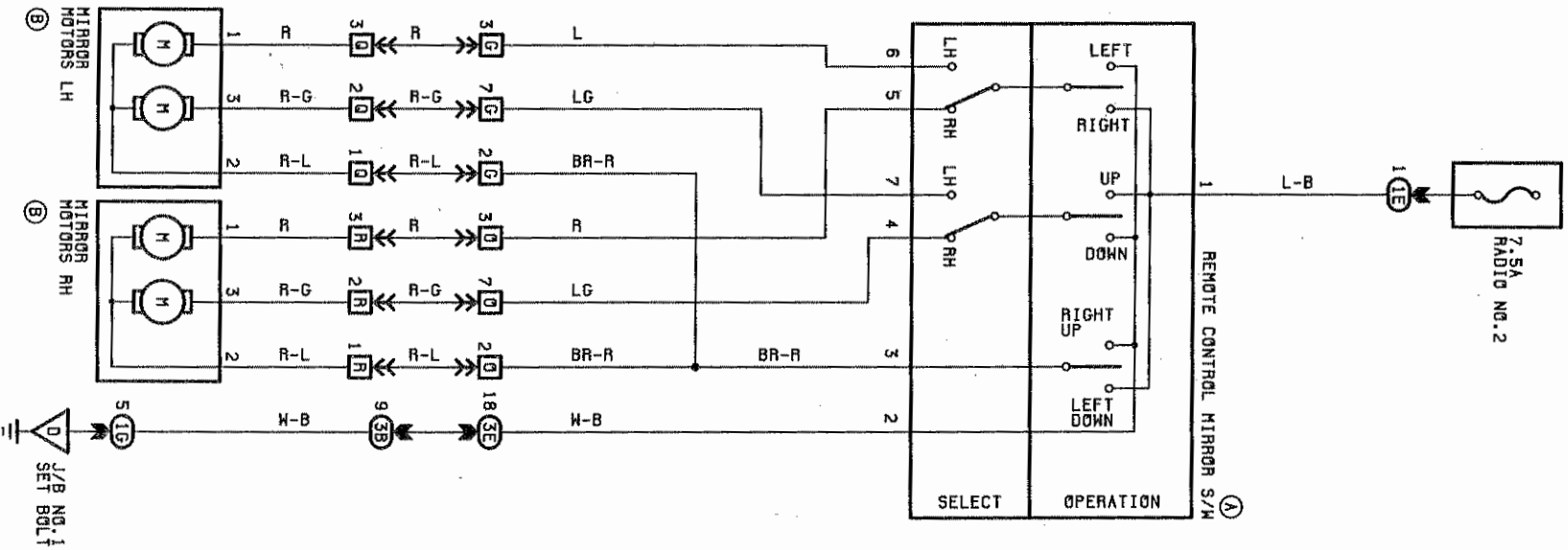

- Ⓐ CRUISE CONTROL COMPUTER**  
 (DISCONNECT THE COMPUTER CONNECTOR)  
 10-GROUND: 12 VOLTS WITH IGNITION S/W AND MAIN S/W ON (POWER)  
 13-GROUND: CONTINUITY (GROUND)  
 7-GROUND: 1 PULSE EACH 40CM (15.75IN) (DRIVE VEHICLE SLOWLY)  
 5-GROUND: CONTINUITY WITH SET, COAST S/W ON  
 17-GROUND: CONTINUITY WITH RESUME, ACCEL S/W ON  
 18-GROUND: ALWAYS 12 VOLTS  
 15-GROUND: 12 VOLTS WITH BRAKE PEDAL DEPRESSED  
 (ONE OF THE CANCEL S/W)  
 11-GROUND: CONTINUITY WITH CLUTCH PEDAL DEPRESSED (USA M/T)  
 12-GROUND: CONTINUITY WITH PARKING BRAKE LEVER PULL UP  
 (ONE OF THE CANCEL S/W)
- Ⓑ CRUISE CONTROL S/W**  
 4-14: 30Ω (ACTUATOR CONTROL VALVE)  
 2-14: 68Ω (ACTUATOR RELEASE VALVE)  
 3-8, 3-5: CLOSED WITH IGNITION S/W ON,  
 MAIN S/W PUSHED IN  
 OPEN WITH IGNITION S/W ON,  
 MAIN S/W PUSHED AGAIN

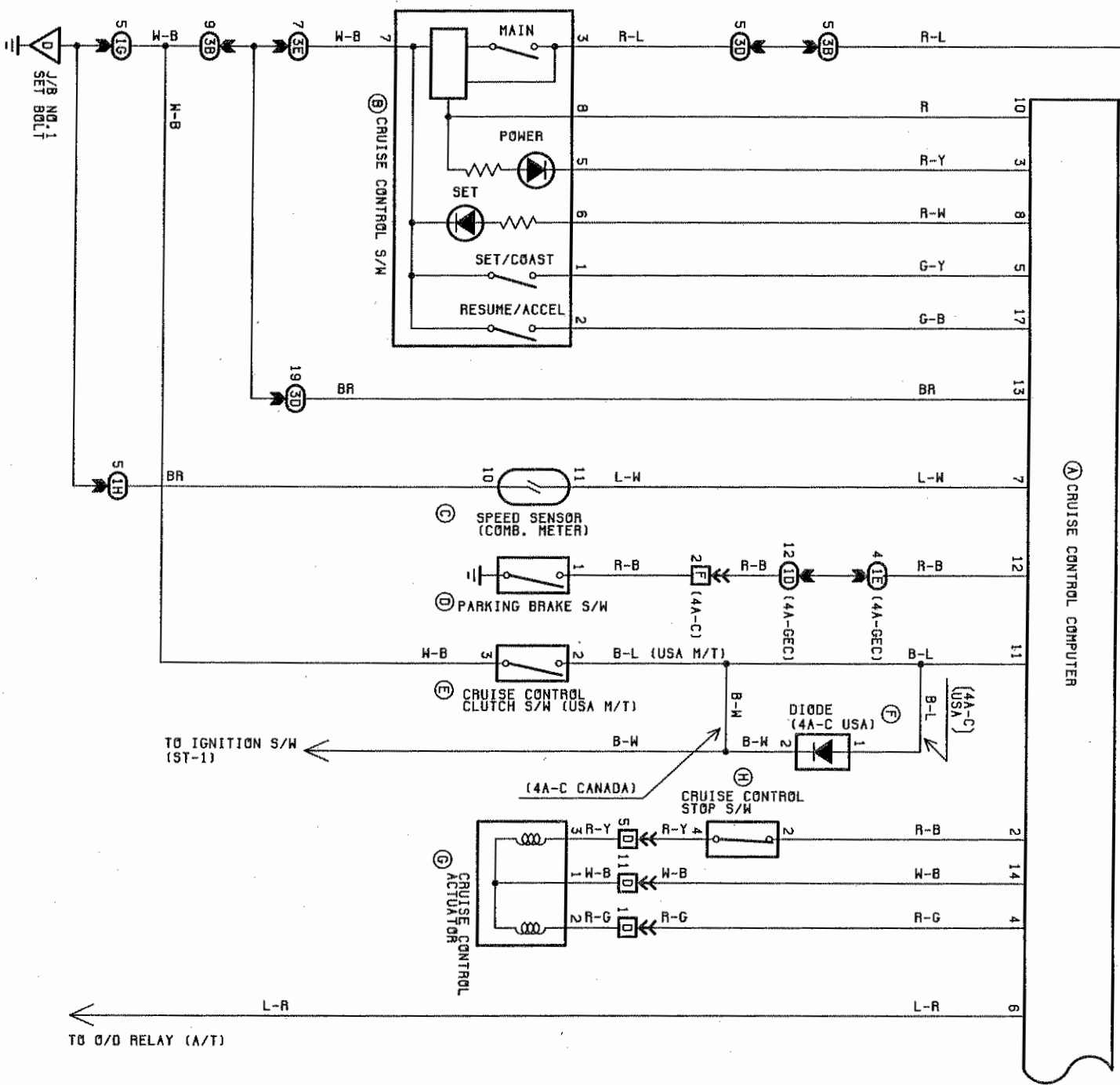

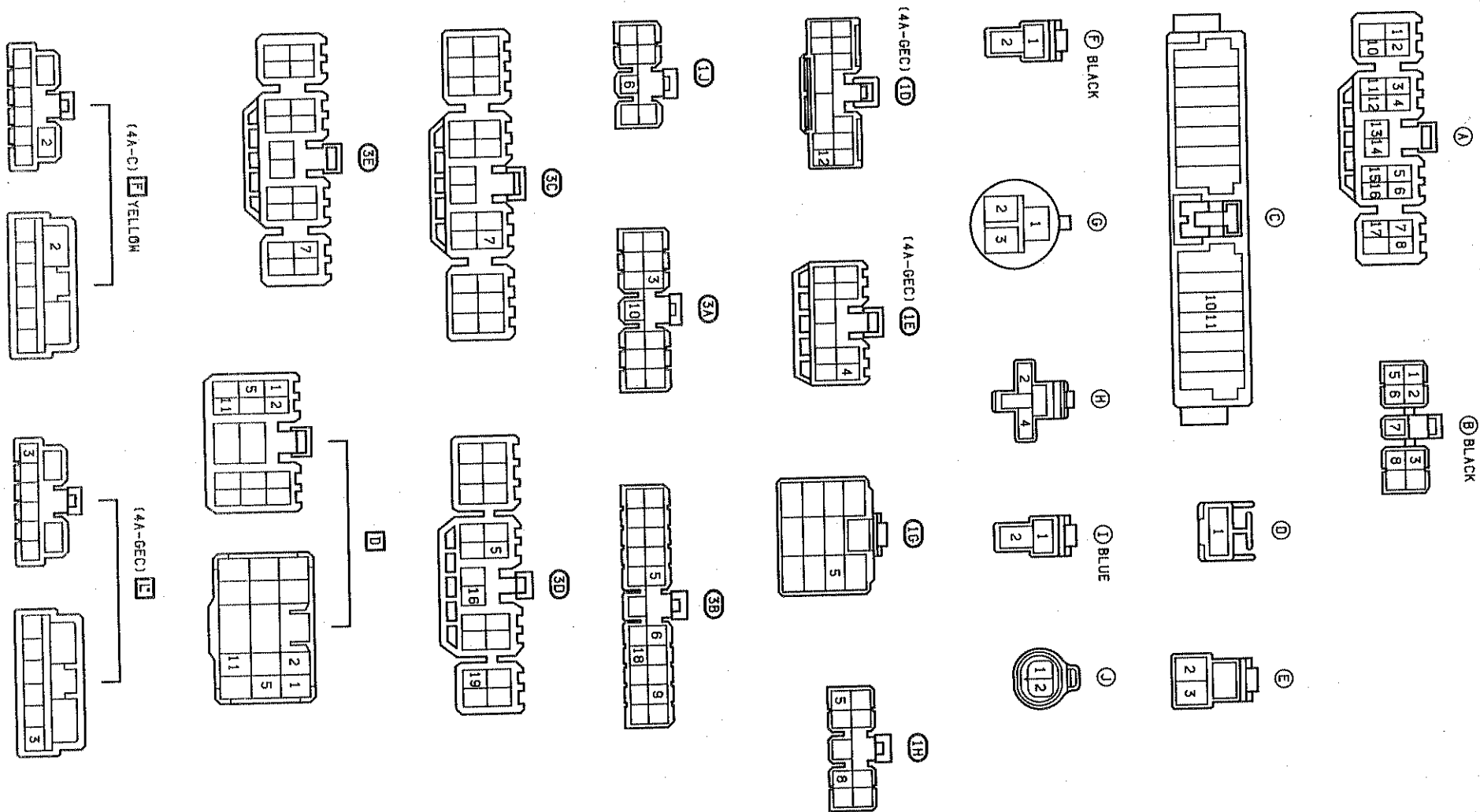
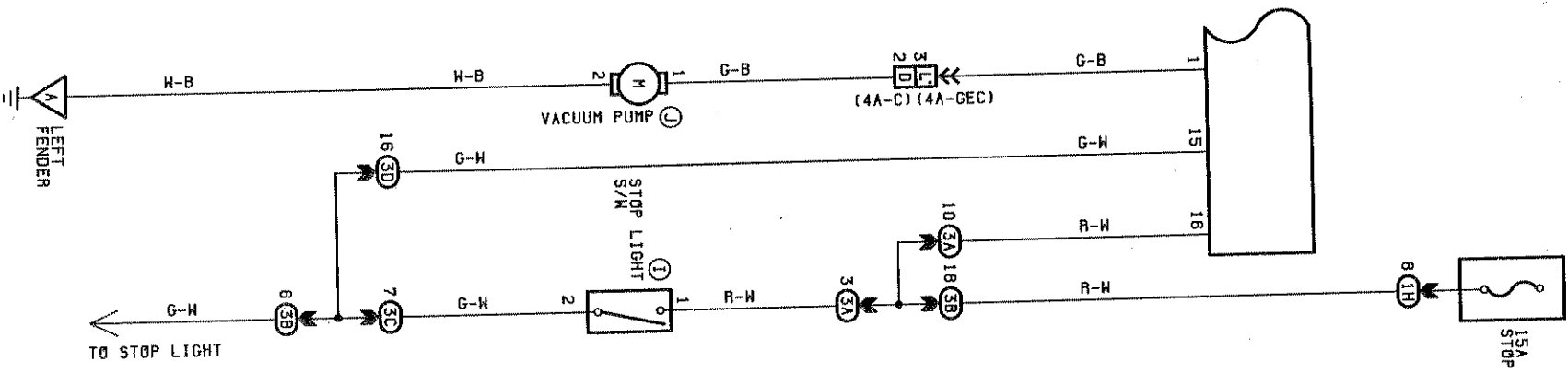

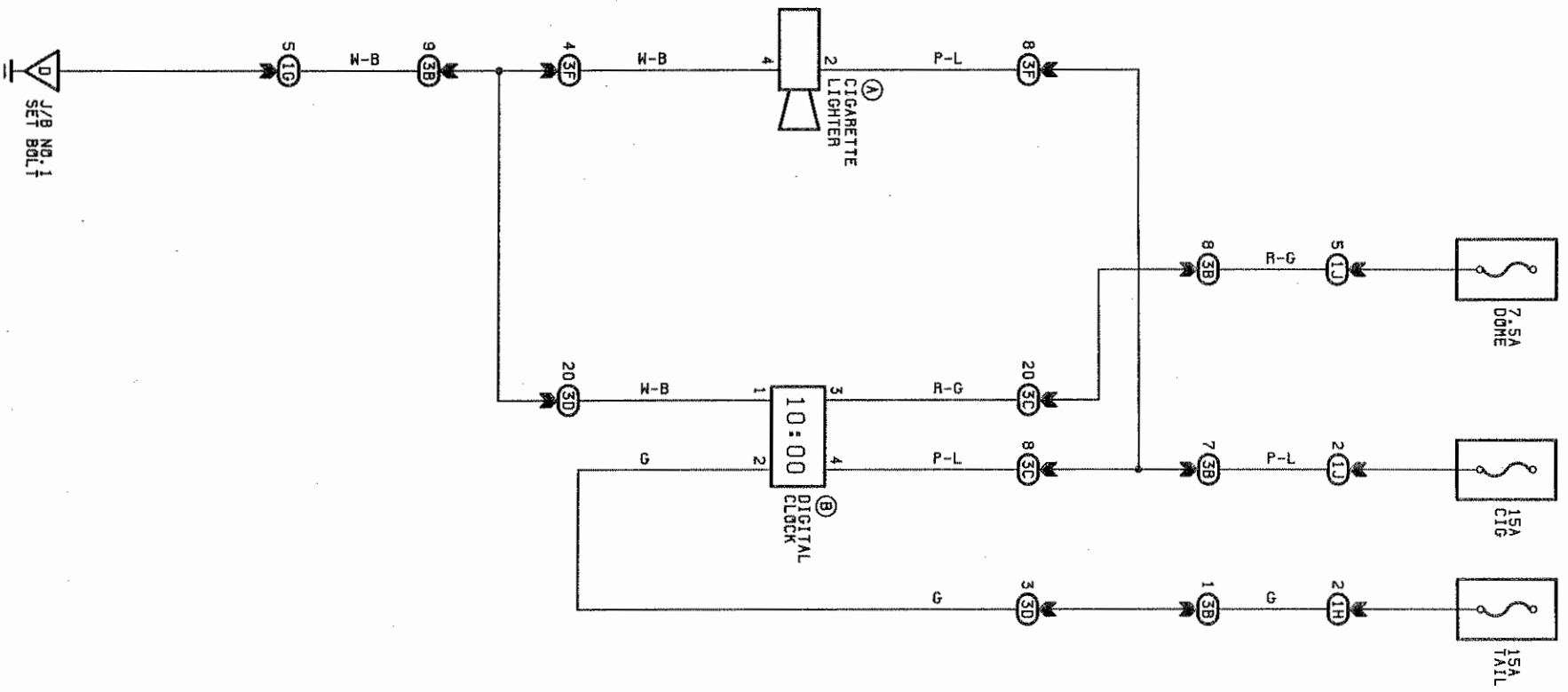

**DIGITAL CLOCK**  
 (B) 3-GROUND  
 ALWAYS 12 VOLTS (POWER FOR CLOCK)  
 (B) 4-GROUND  
 12 VOLTS WITH IGNITION S/M AT IG OR ACC  
 POSITION (POWER FOR INDICATION)  
 (B) 2-GROUND  
 12 VOLTS WITH LIGHT CONTROL S/M AT TAIL  
 OR HEAD POSITION (SIGNAL OF DIM INDICATION)

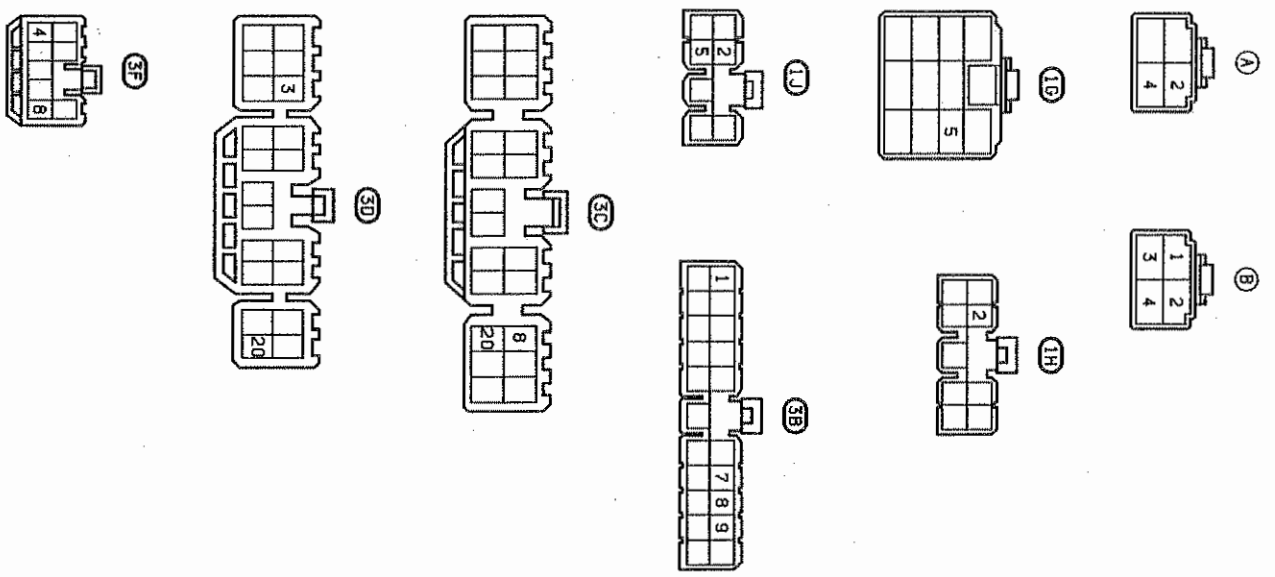



# SUN ROOF 23

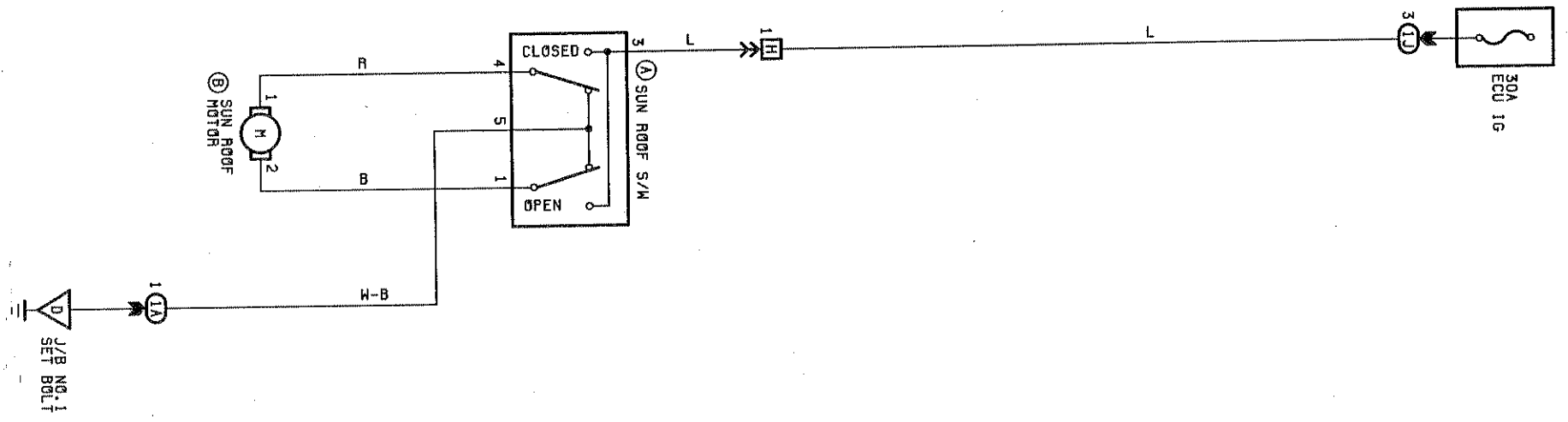
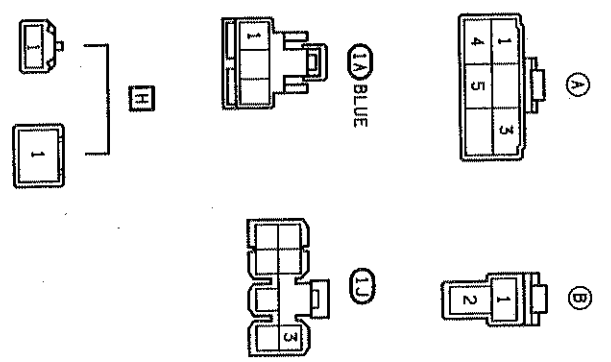

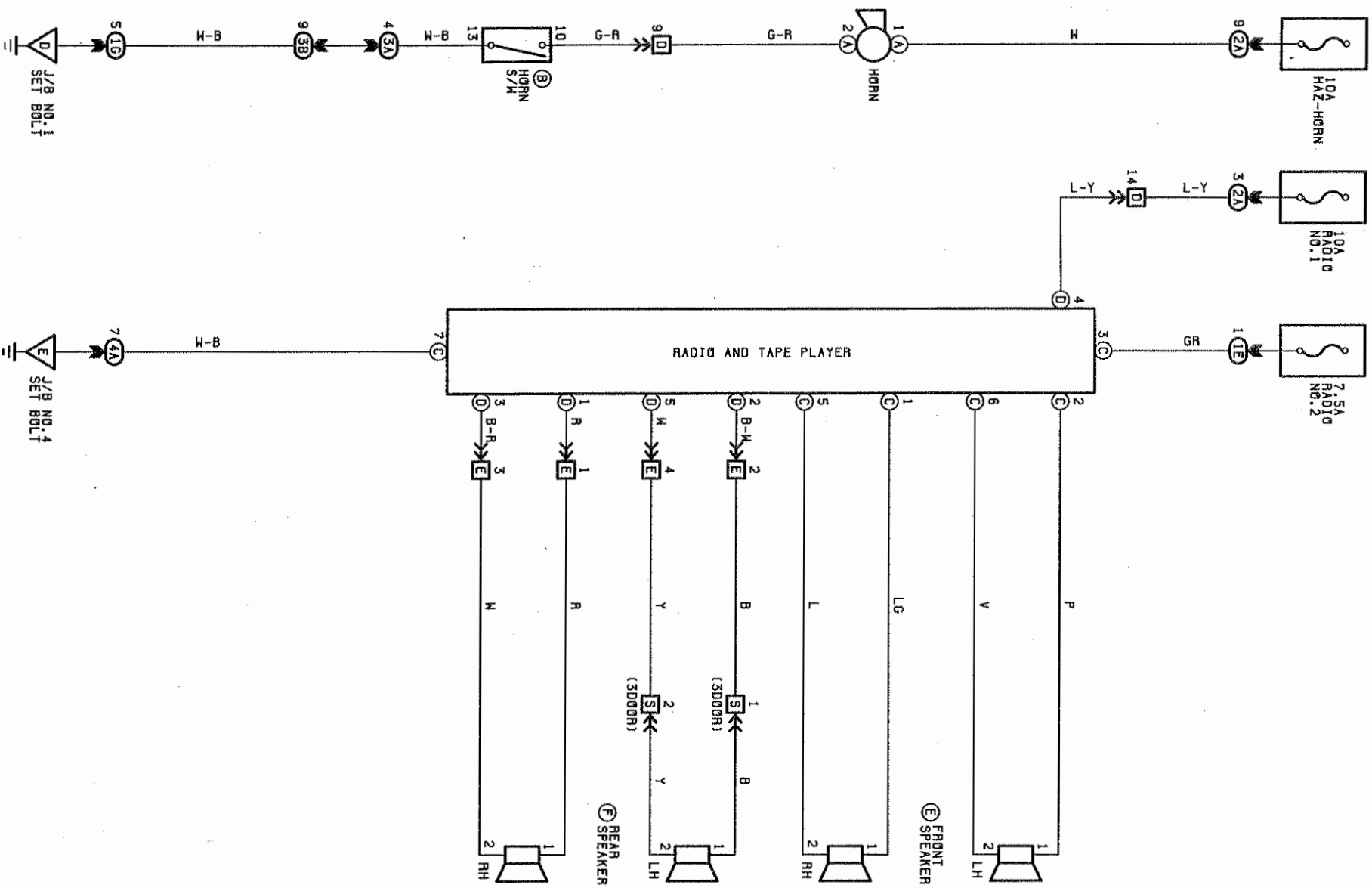

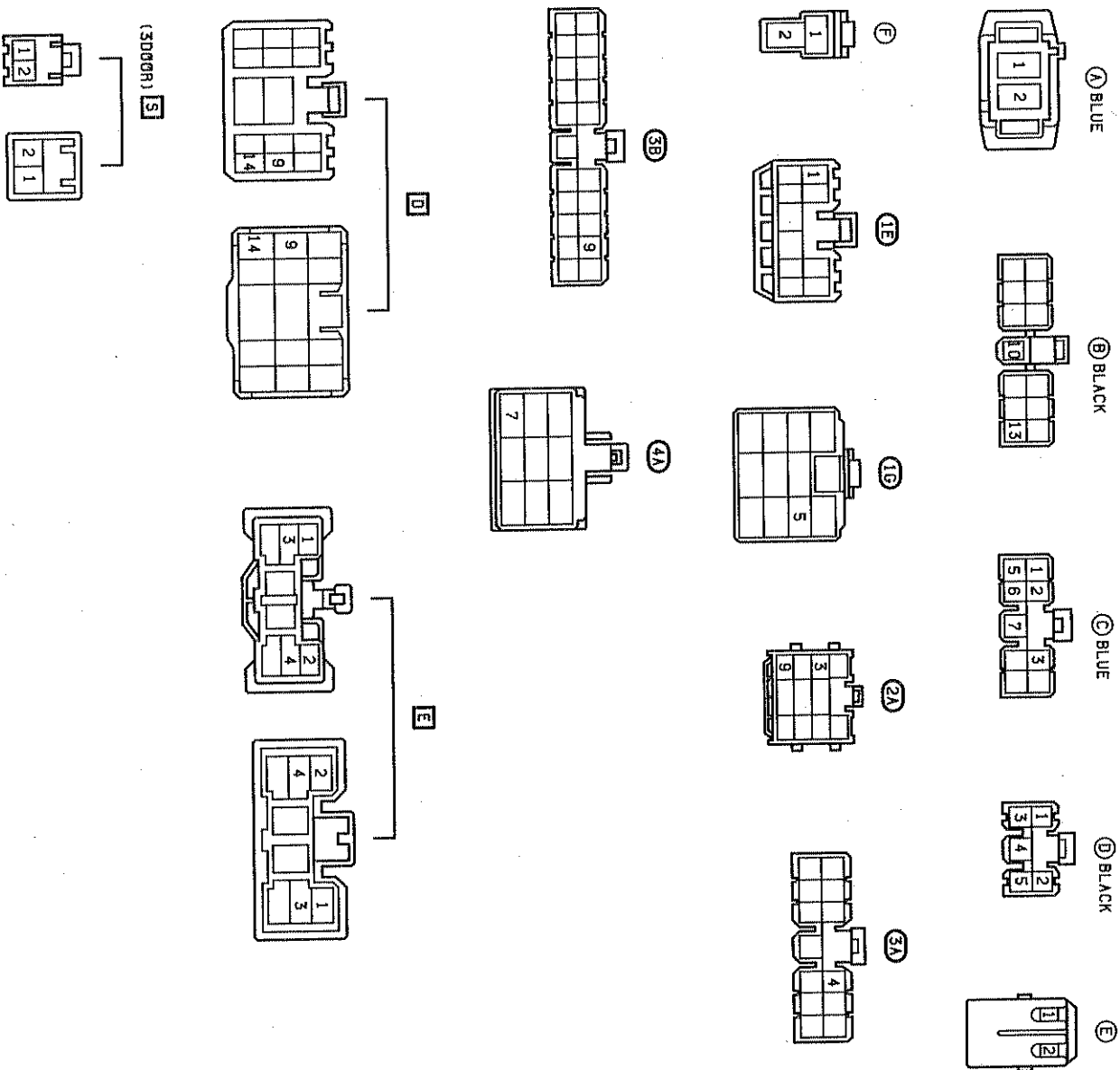

# 25 COMBINATION METER

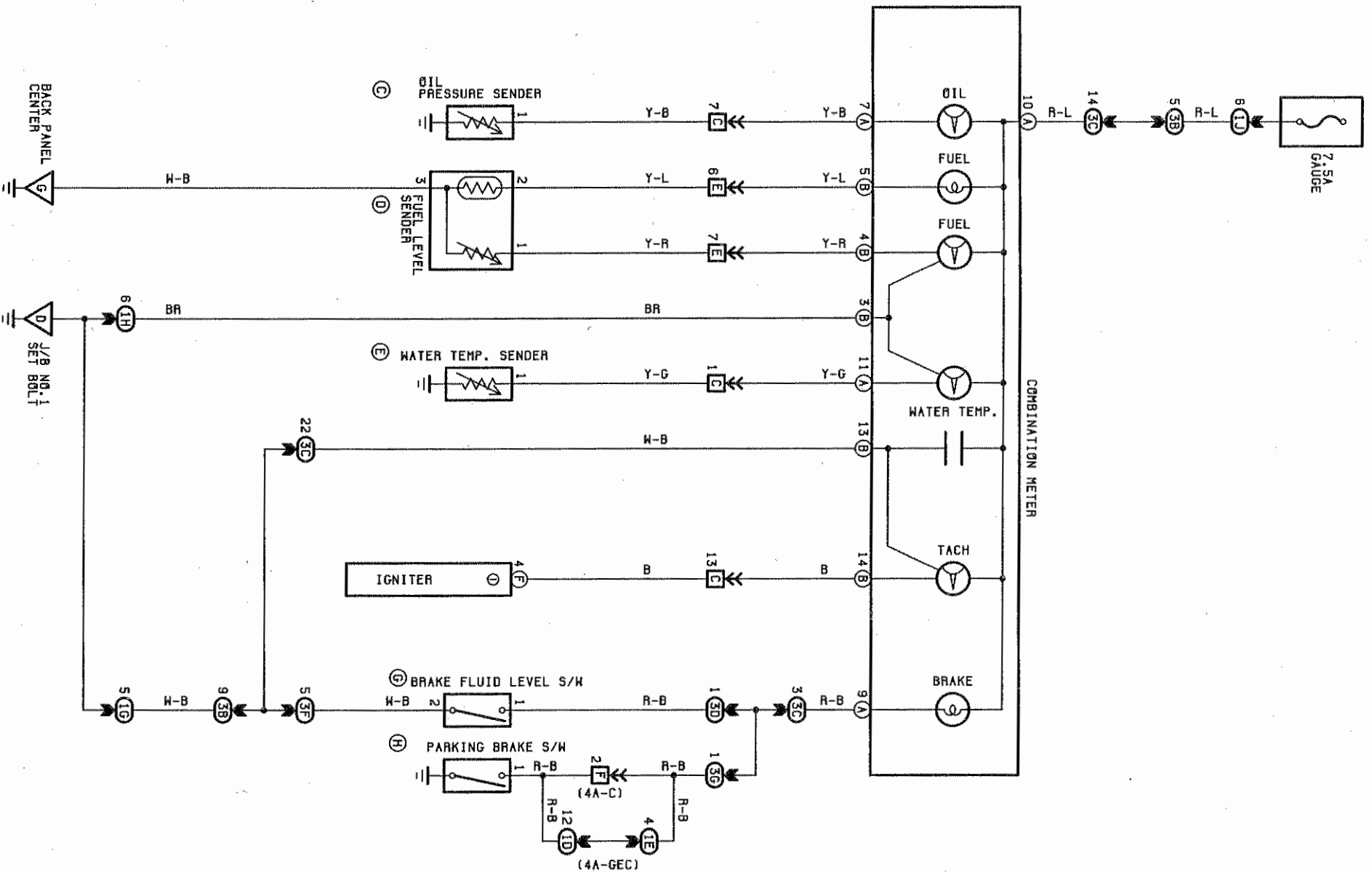

**ⓓ FUEL LEVEL SENDER**

1-GROUND: APPROX. 5 Ω WITH FUEL FULL  
 APPROX. 32.5 Ω WITH FUEL HALF FULL  
 APPROX. 110 Ω WITH FUEL EMPTY

**ⓔ WATER TEMP. SENDER**

1-GROUND: APPROX. 228 Ω AT 50°C (122°F)  
 APPROX. 26.4 Ω AT 115°C (239°F)

**ⓖ BRAKE FLUID LEVEL S/W**

1-2: CLOSED WITH FLOAT DOWN

**ⓗ PARKING BRAKE S/W**

1-GROUND: CLOSED WITH PARKING BRAKE LEVER PULLED UP

Ⓝ BLUE

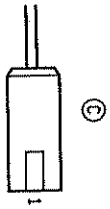
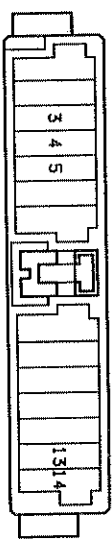
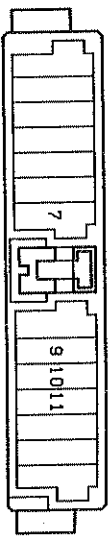

ⓐ

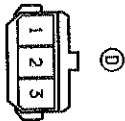

ⓑ



ⓒ

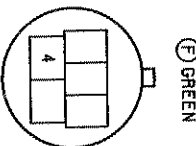

ⓓ GREEN

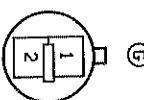

ⓔ



ⓕ

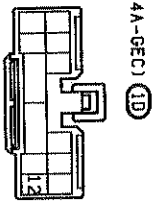

(14A-GE) ⓖ

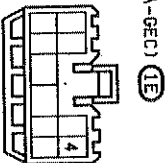

(14A-GE) ⓗ

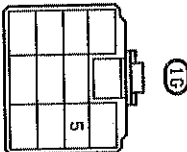

ⓘ

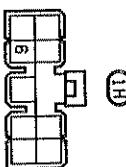

ⓙ

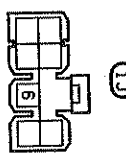

ⓚ

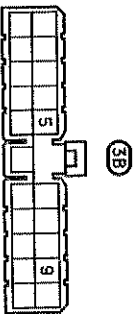

ⓛ

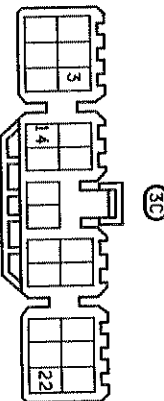

ⓓ

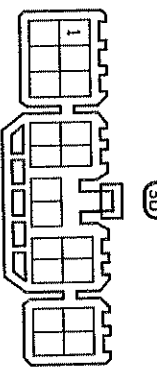

ⓔ

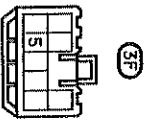

ⓕ

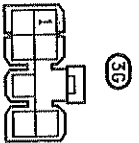

ⓖ

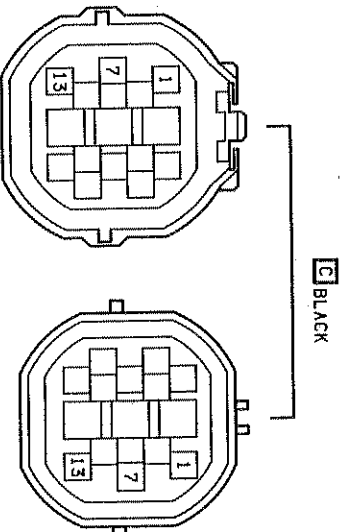

ⓗ BLACK

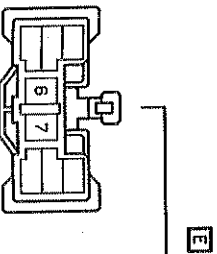

ⓓ

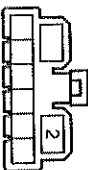
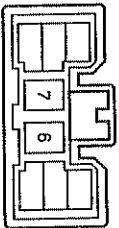

(14A-C) ⓕ



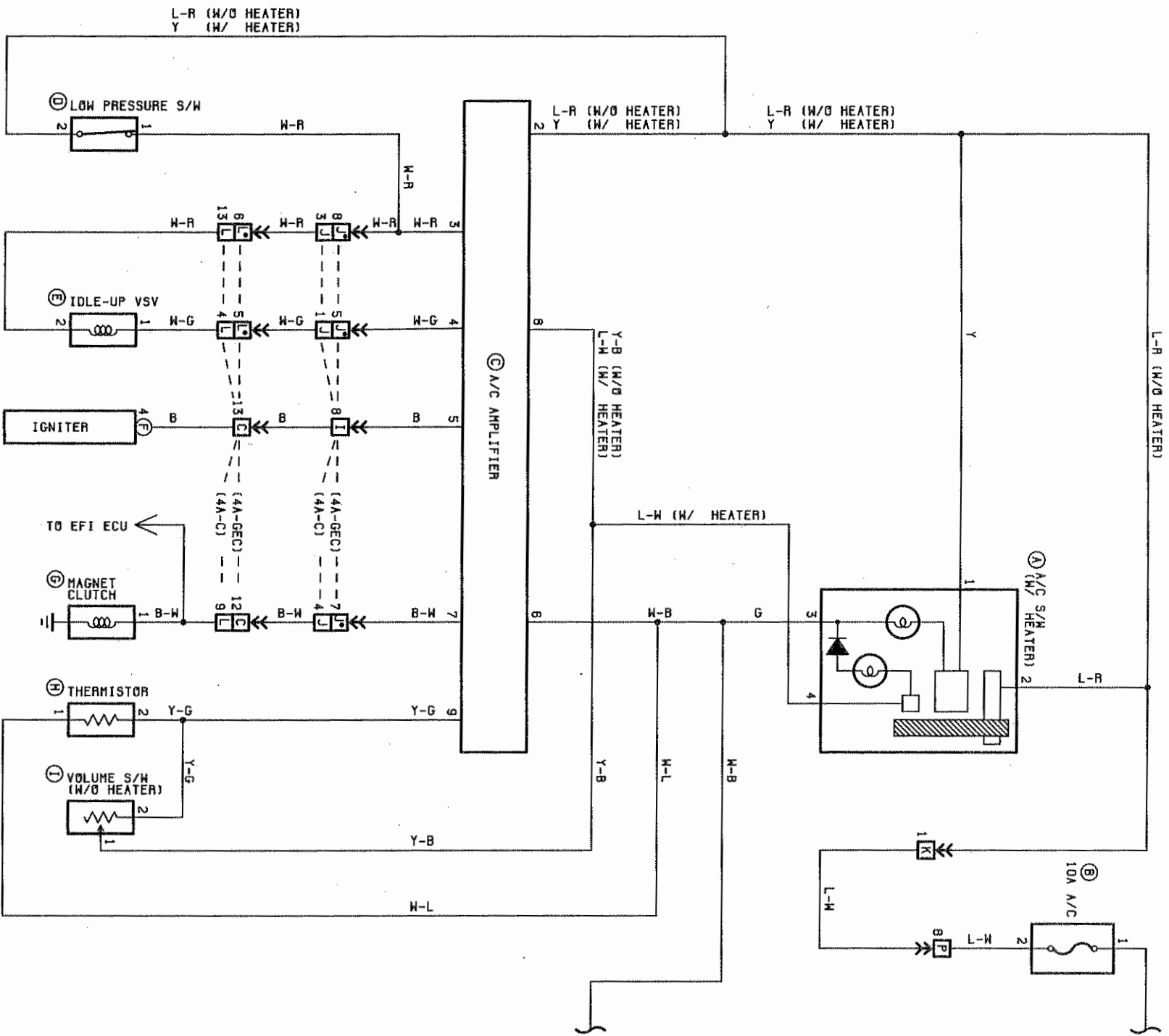

- (D) **LOW PRESSURE S/W**  
1-2: OPEN WITH PRESSURE LESS THAN 2.1KG/CM<sup>2</sup> (30PSI, 206KPA)
- (E) **IDLE-UP VSV**  
1-2: APPROX. 40Ω
- (G) **MAGNET CLUTCH**  
1-GROUND: APPROX. 5.7Ω
- (H) **THERMISTOR**  
1-2: APPROX. 4.8KΩ AT 0°C (32°F)  
APPROX. 4.4KΩ AT 2°C (36°F)  
APPROX. 4.0KΩ AT 4°C (39°F)
- (K) **HEATER RELAY**  
4-5: CLOSED WITH IGNITION S/W ON AND BLOWER S/W ON
- (N) **BLOWER RESISTOR**  
1-2: APPROX. 2.1Ω  
2-4: APPROX. 0.75Ω  
3-4: APPROX. 0.2Ω

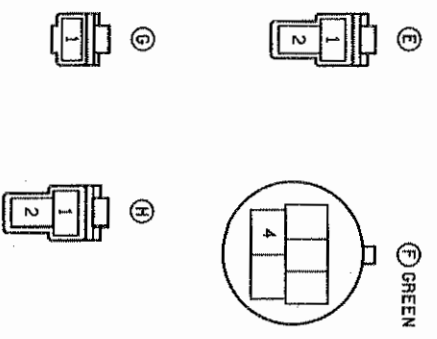
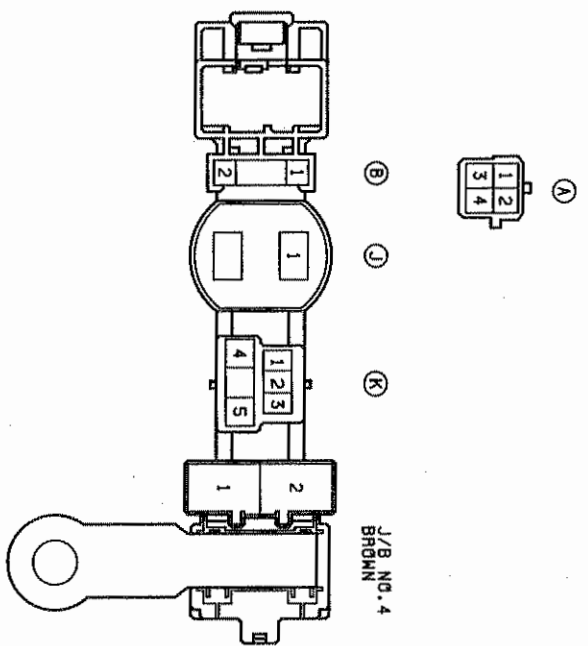
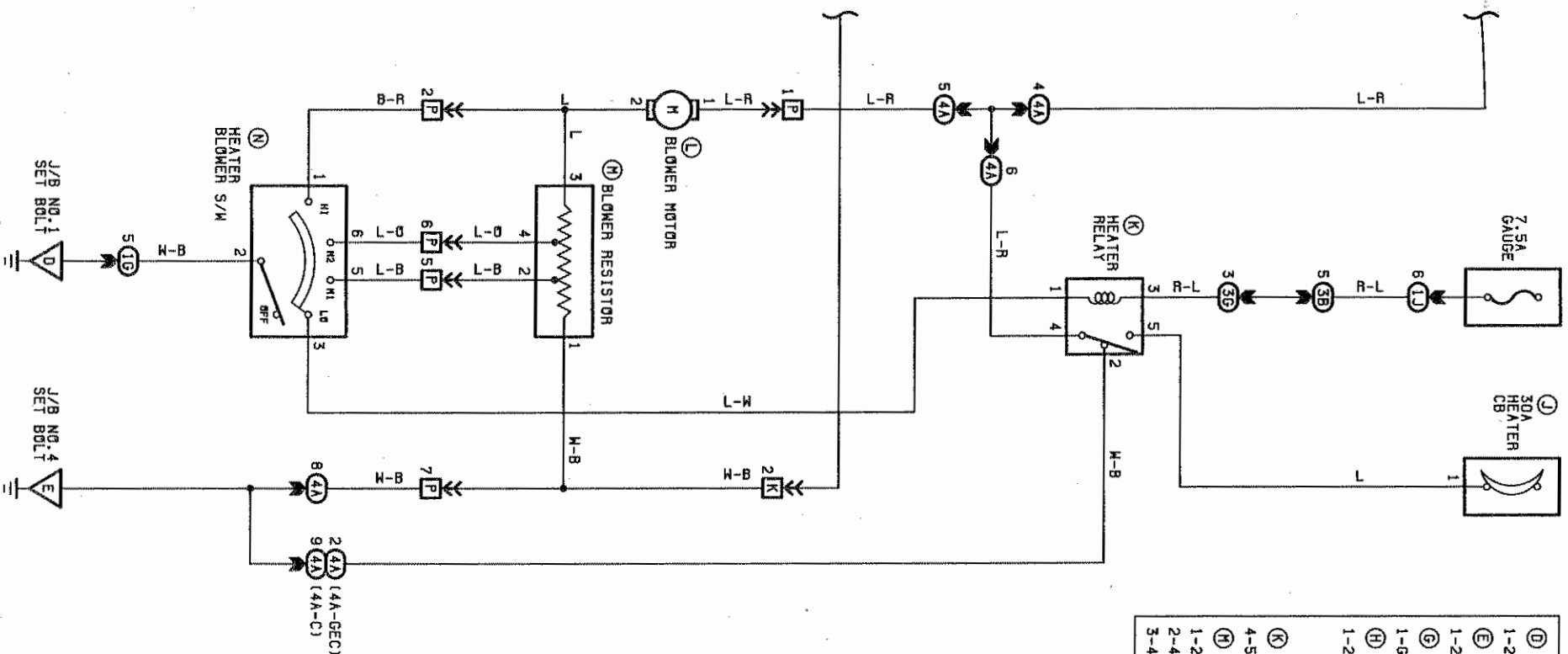





# AIR CONDITIONER (4A-GEC WITH P/S) 26-2

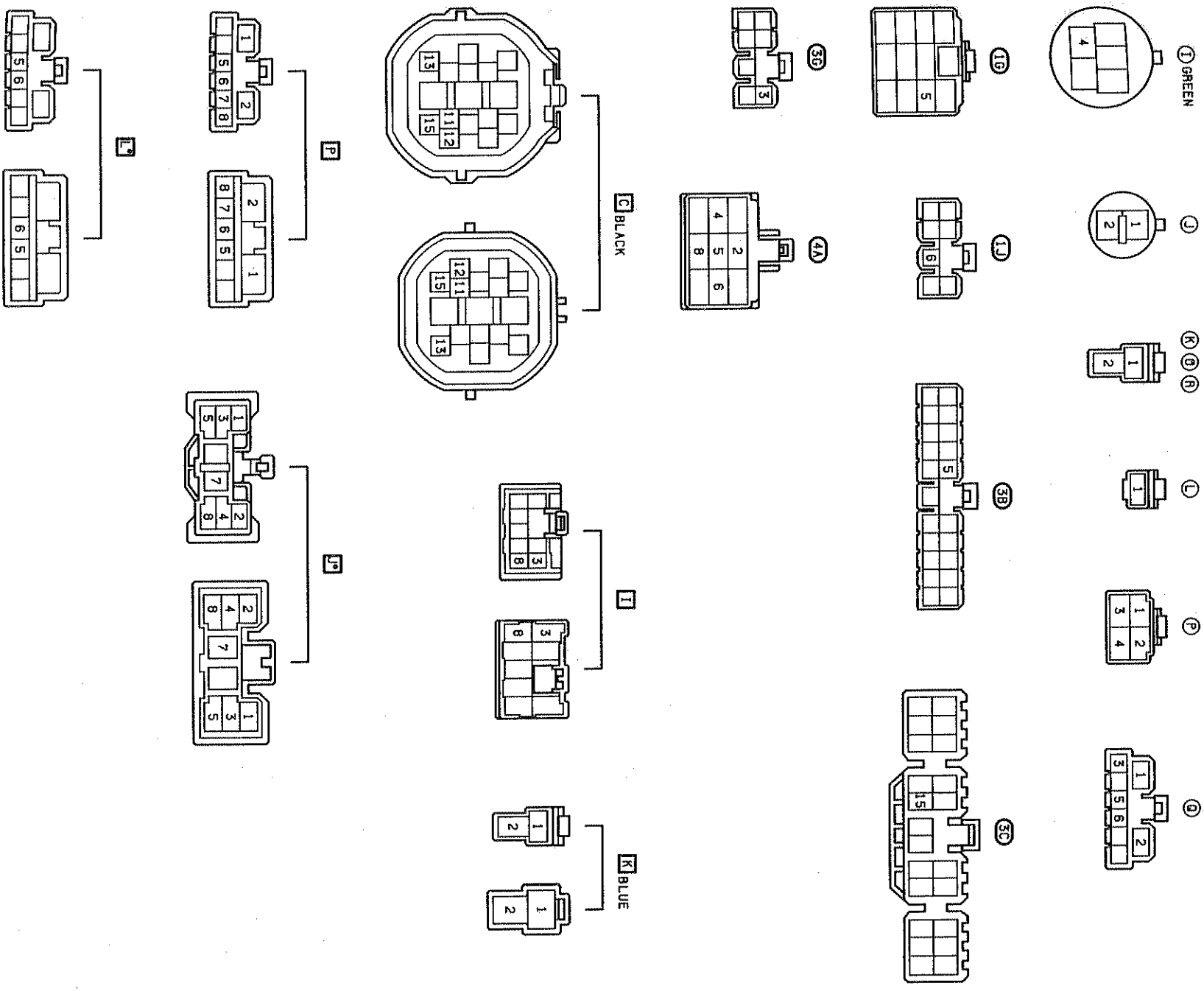

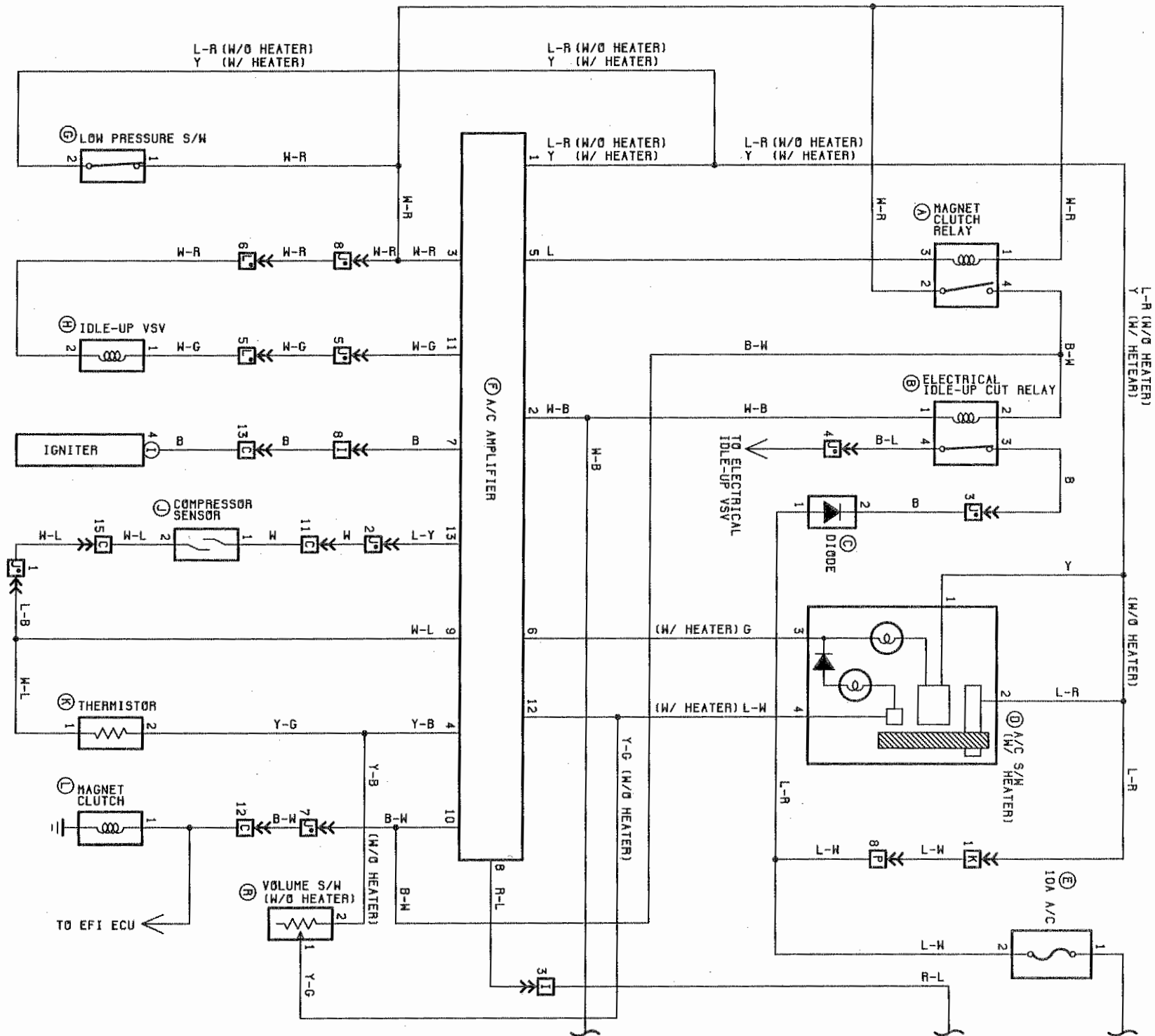

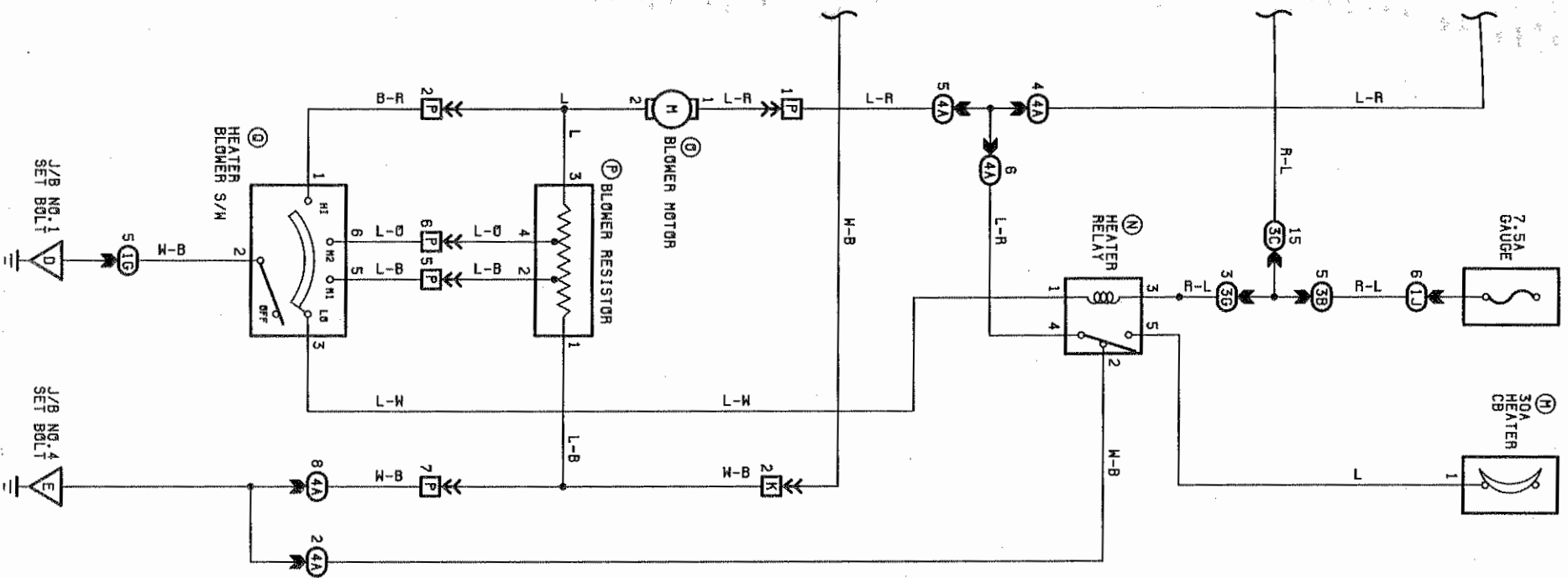

- (A) **MAGNET CLUTCH RELAY**  
 2-4: CLOSED WITH IGNITION S/W, A/C S/W AND LOW PRESSURE S/W ON (POWER FOR MAGNET CLUTCH)  
 (B) **ELECTRICAL IDLE-UP CUT RELAY**  
 3-4: OPEN WITH MAGNET CLUTCH RELAY 2-4; CLOSED  
 (C) **LOW PRESSURE S/W**  
 1-2: OPEN WITH PRESSURE LESS THAN 2.1KG/CM<sup>2</sup> (30PST, 206KPA)  
 (H) **IDLE-UP VSV**  
 1-2: APPROX. 40 Ω  
 (K) **THERMISTOR**  
 1-2: APPROX. 4.8KΩ AT 0°C (32°F)  
 APPROX. 4.4KΩ AT 2°C (36°F)  
 APPROX. 4.0KΩ AT 4°C (39°F)  
 (L) **MAGNET CLUTCH**  
 1-GROUND; APPROX. 3.7 Ω  
 (N) **HEATER RELAY**  
 4-5: CLOSED WITH IGNITION S/W ON AND BLOWER S/W ON  
 (P) **BLOWER RESISTOR**  
 1-2: APPROX. 2.1 Ω  
 2-4: APPROX. 0.73 Ω  
 3-4: APPROX. 0.2 Ω

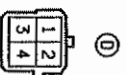
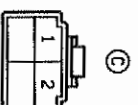
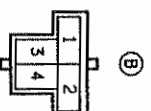
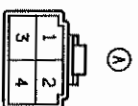

(E)

(H)

(N)

(P)

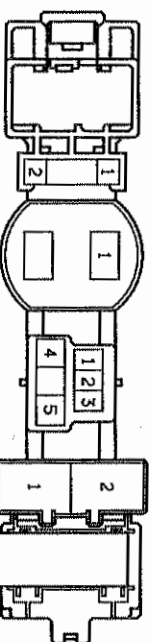
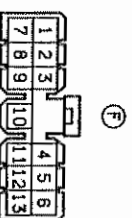
J/B NO. 4  
BROWNHEATER  
BLOWER S/WHEATER  
BLOWER S/W

(G)

(H)



(J)

J/B NO. 1  
SET BOLTJ/B NO. 4  
SET BOLTHEATER  
BLOWER S/WHEATER  
BLOWER S/W

# 27 GROUND POINTS

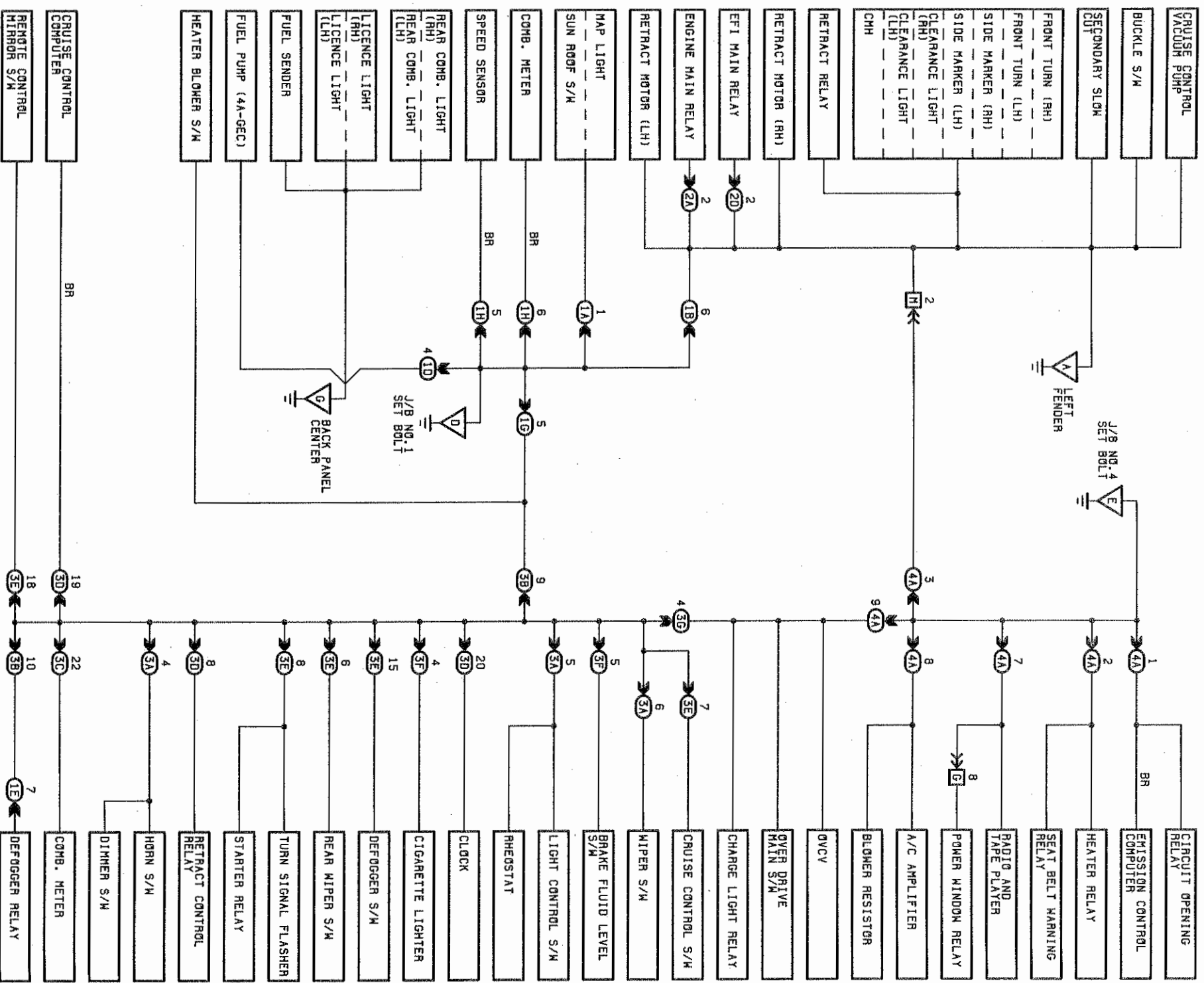

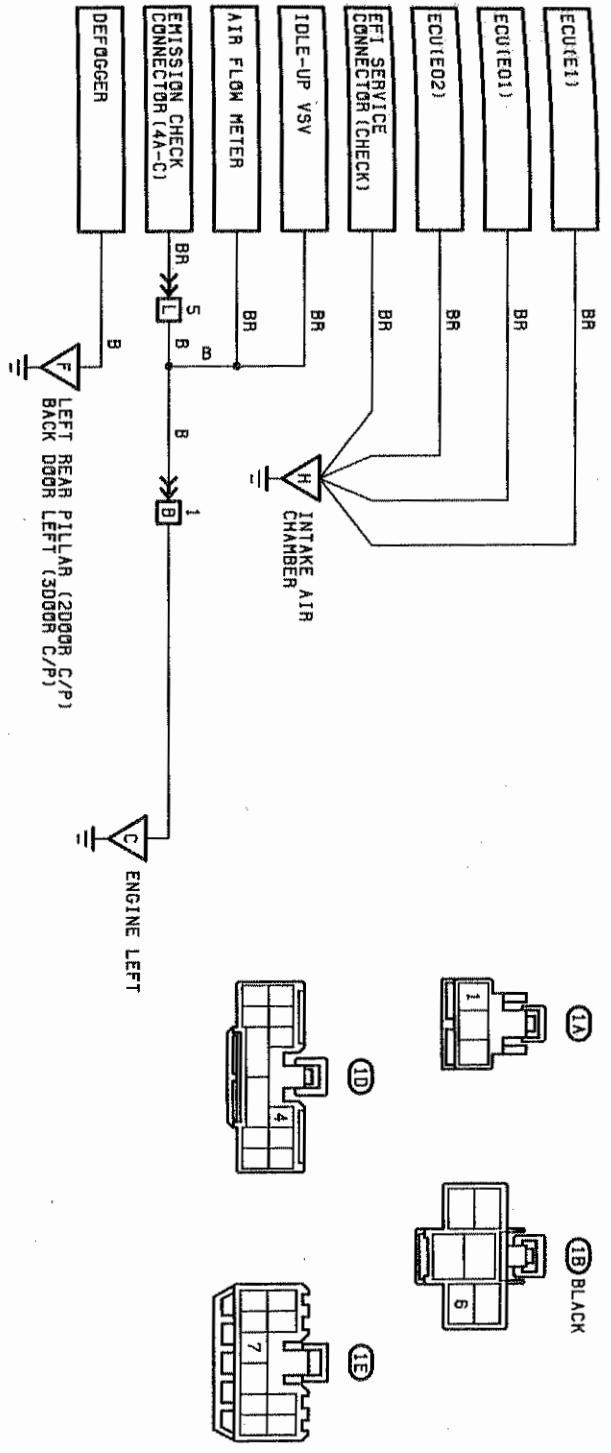

1A

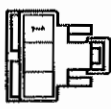

1B BLACK

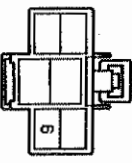

1D

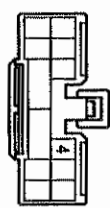

1E

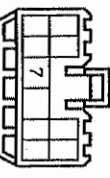

2D ORANGE

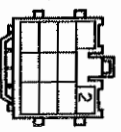

3A



1G

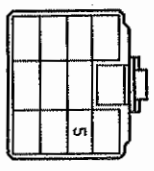

1H

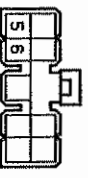

2A

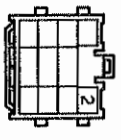

3B

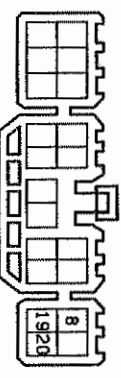

3B



3C

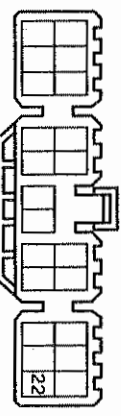

3E

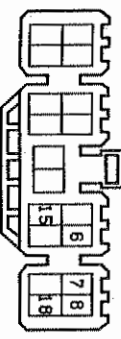

3F

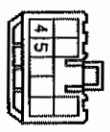

3G

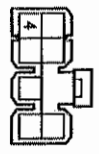

4A

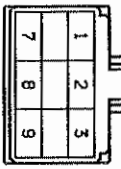

J/B NO. 4 BROWN

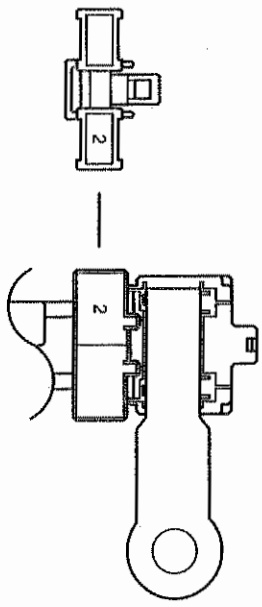

B

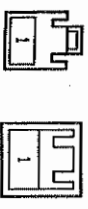

C



4A-C1

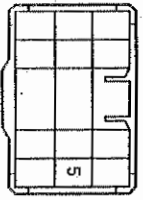
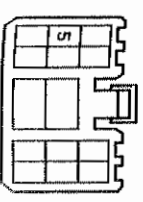

# RELAY LOCATIONS

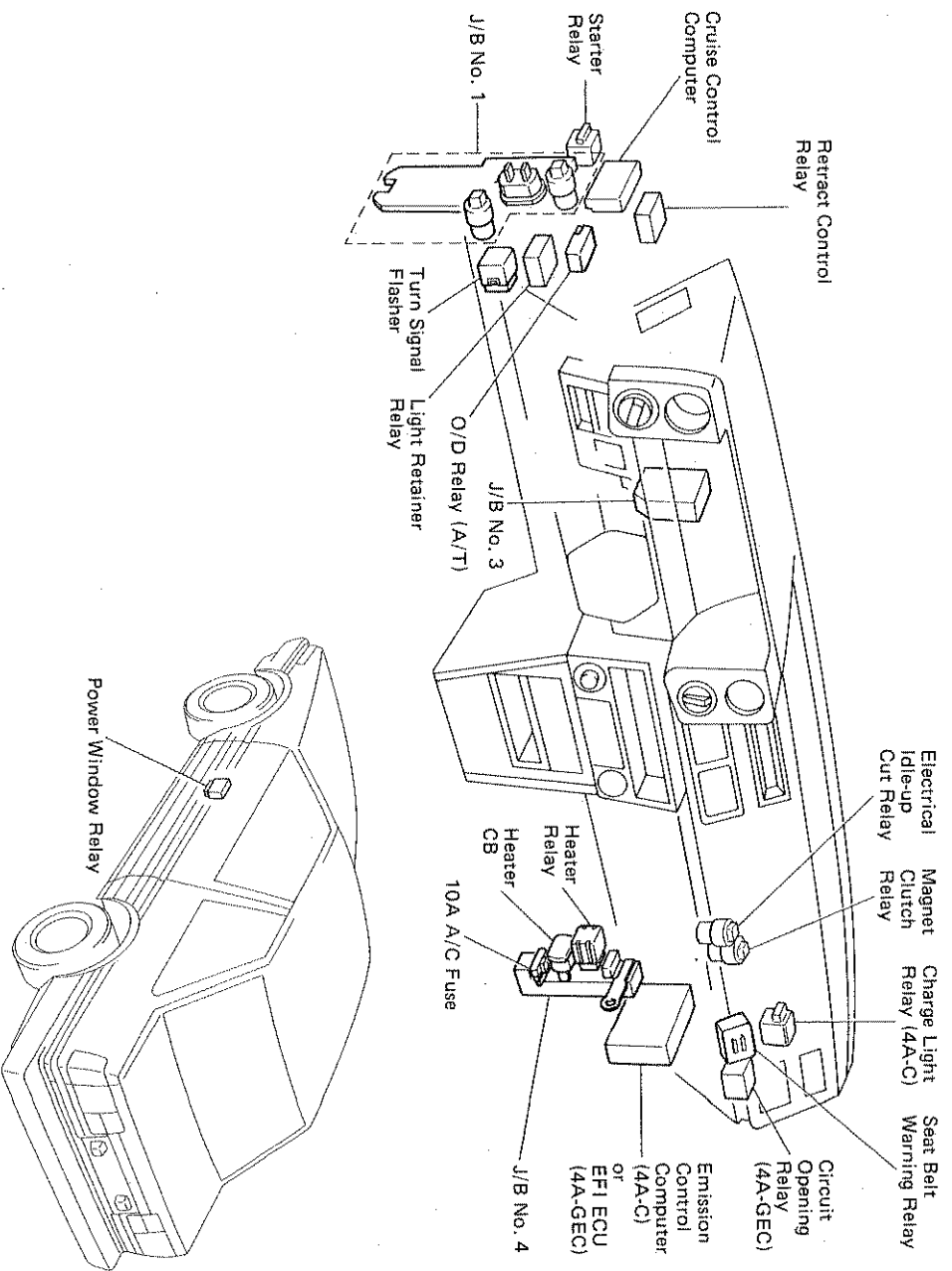
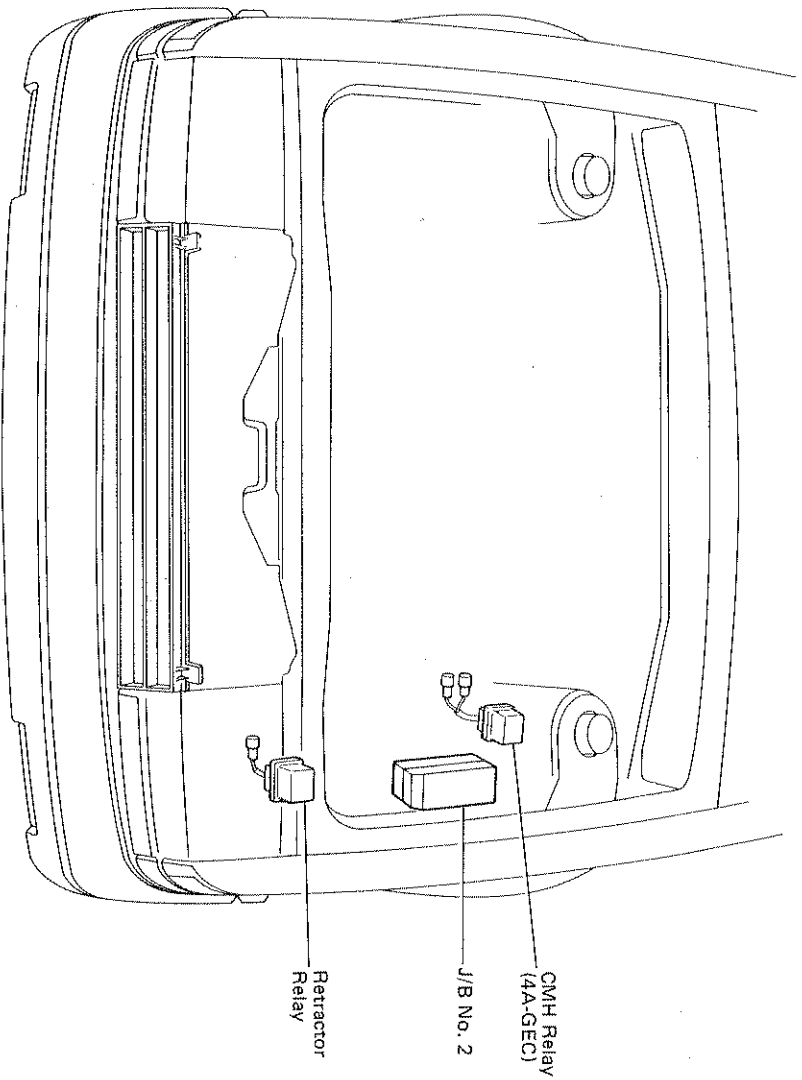

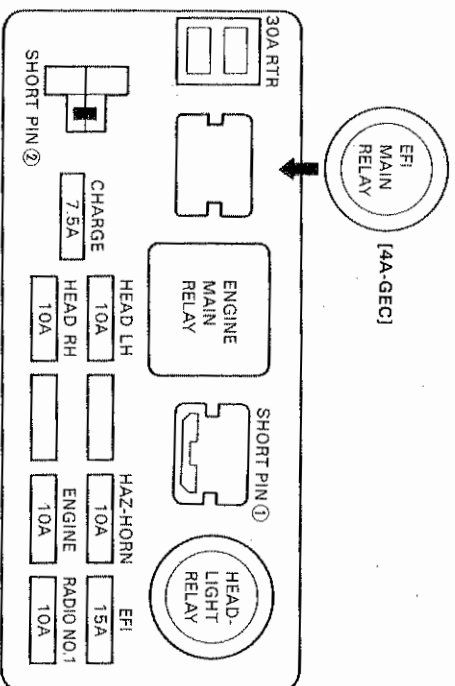

J/B NO. 2

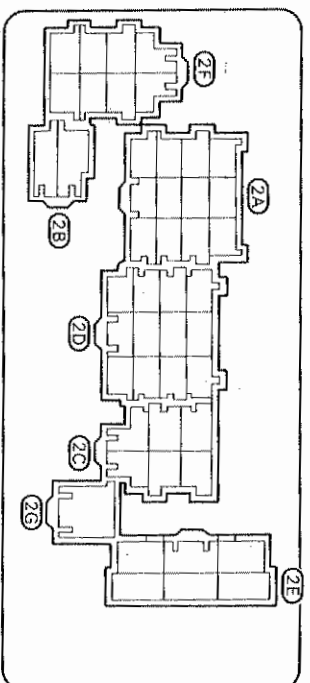

J/B NO. 1

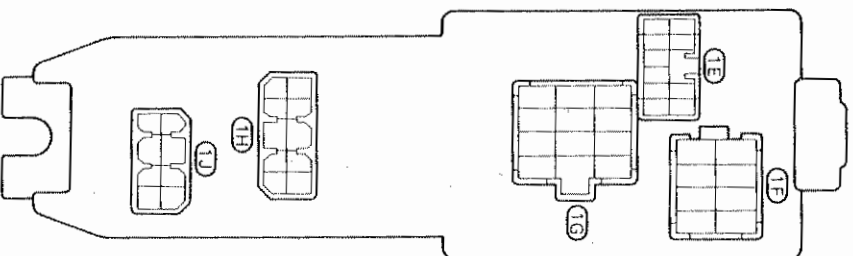
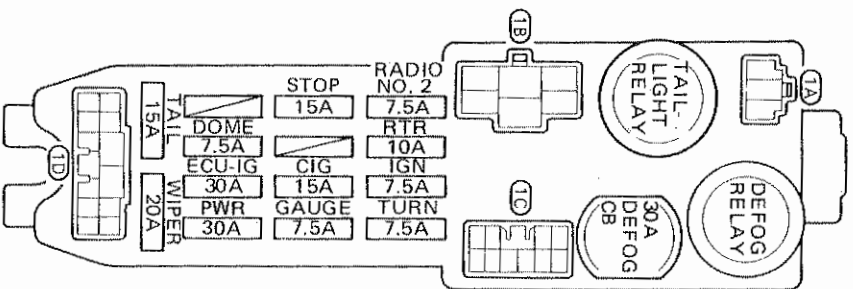

J/B NO. 3

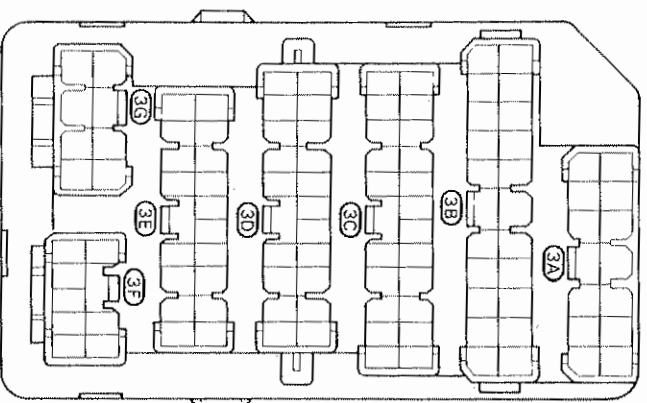

# ELECTRICAL WIRING ROUTING

[4A-C]

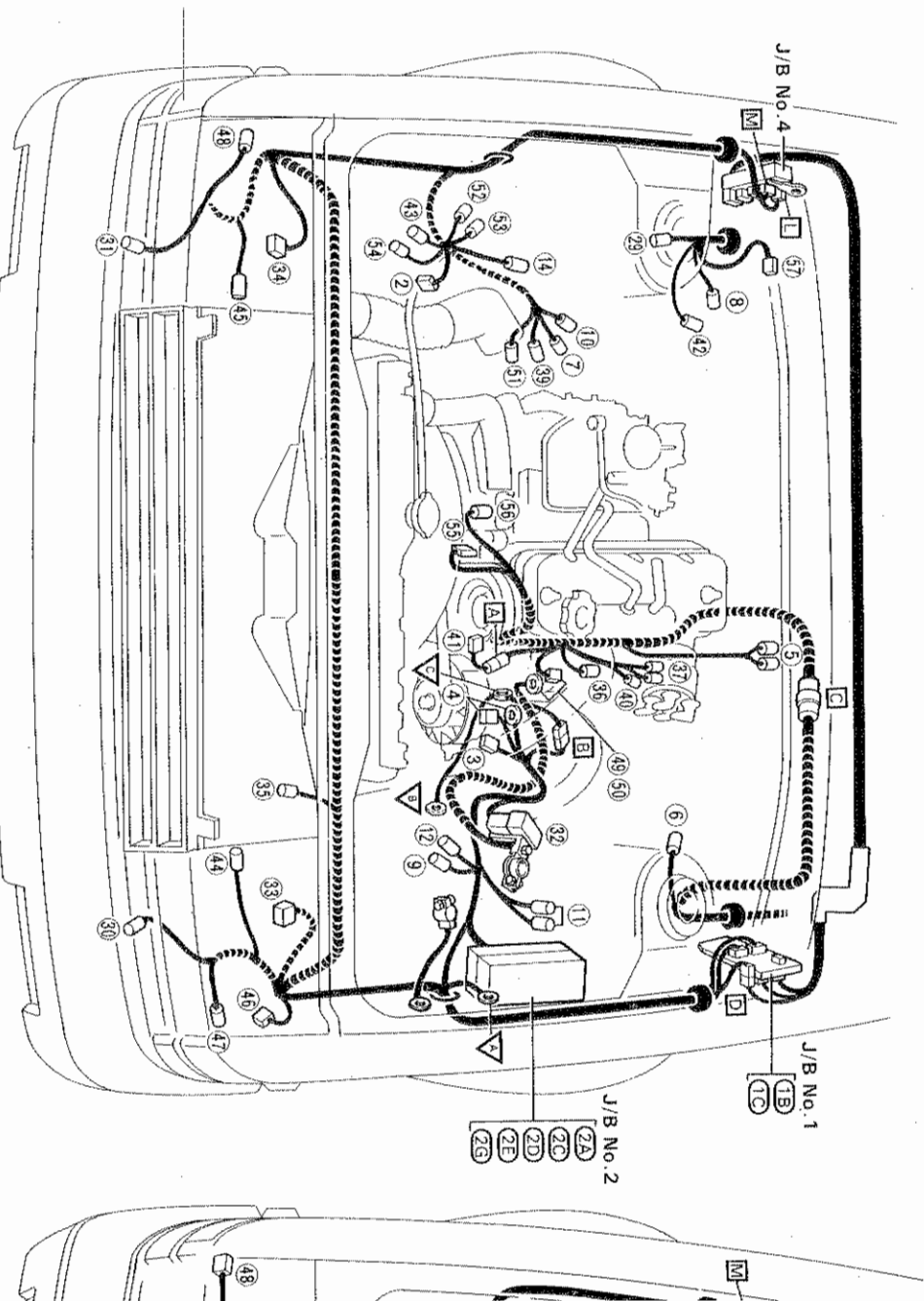

- ① A/C Compressor Sensor
- ② A/C Idle-up VSV
- ③ A/C Magnet Clutch
- ④ Alternator
- ⑤ Back-up Light S/W (M/T)
- ⑥ Brake Fluid Level S/W
- ⑦ Carburetor  
(Choke Heater, Fuel Cut, Secondary Slow Cut)
- ⑧ Check Connector (EMISSION CONTROL)
- ⑨ Cruise Control Vacuum Pump
- ⑩ CMH (USA)
- ⑪ CMH Relay (USA)
- ⑫ Cruise Control Actuator
- ⑬ Distributor (4A-GEC)
- ⑭ EBCV
- ⑮ EFI Air Flow Meter
- ⑯ EFI Cold Start Injector
- ⑰ EFI Injector
- ⑱ EFI Injector
- ⑳ EFI Injector

- ㉑ EFI Ox Sensor
- ㉒ EFI Resistor
- ㉓ EFI Service Connector (Check Connector)
- ㉔ EFI Start Injector Time S/W
- ㉕ EFI Throttle Position Sensor
- ㉖ EFI VSV (T-VIS)
- ㉗ EFI Water Thermo Sensor
- ㉘ Electrical Idle-up VSV
- ㉙ Evapo Purge VSV
- ㉚ Front Turn Signal Light LH
- ㉛ Front Turn Signal Light RH
- ㉜ Fusible Link Box
- ㉝ Headlight LH
- ㉞ Headlight RH
- ㉟ Horn
- ㊱ I/A or Igniter
- ㊲ Neutral Start S/W and Back-up Light S/W (A/T)
- ㊳ Noise Filter (Ignition System)
- ㊴ Ox Sensor (USA)
- ㊵ O/D Solenoid (A/T)
- ㊶ Oil Pressure Sender

- ㊷ Outer V
- ㊸ Rear W
- ㊹ Retract
- ㊺ Retract
- ㊻ Retract
- ㊼ Side M
- ㊽ Side M
- ㊾ Starter
- ㊿ Thrott
- ① Vacuum
- ② Vacuum
- ③ Washer
- ④ Water
- ⑤ Water
- ⑥ Wiper
- ⑦ Wiper
- ⑧ Wiper
- ⑨ Wiper
- ⑩ Wiper
- ⑪ Wiper
- ⑫ Wiper
- ⑬ Wiper
- ⑭ Wiper
- ⑮ Wiper
- ⑯ Wiper
- ⑰ Wiper
- ⑱ Wiper
- ⑲ Wiper
- ⑳ Wiper
- ㉑ Wiper
- ㉒ Wiper
- ㉓ Wiper
- ㉔ Wiper
- ㉕ Wiper
- ㉖ Wiper
- ㉗ Wiper
- ㉘ Wiper
- ㉙ Wiper
- ㉚ Wiper
- ㉛ Wiper
- ㉜ Wiper
- ㉝ Wiper
- ㉞ Wiper
- ㉟ Wiper
- ㊱ Wiper
- ㊲ Wiper
- ㊳ Wiper
- ㊴ Wiper
- ㊵ Wiper
- ㊶ Wiper
- ㊷ Wiper
- ㊸ Wiper
- ㊹ Wiper
- ㊺ Wiper
- ㊻ Wiper
- ㊼ Wiper
- ㊽ Wiper
- ㊾ Wiper
- ㊿ Wiper



[4A-GEC]

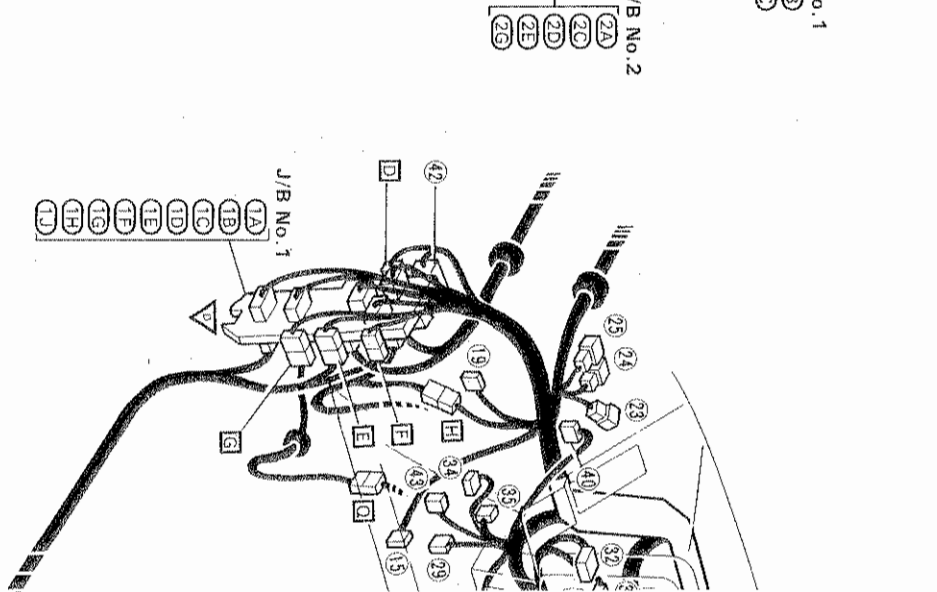
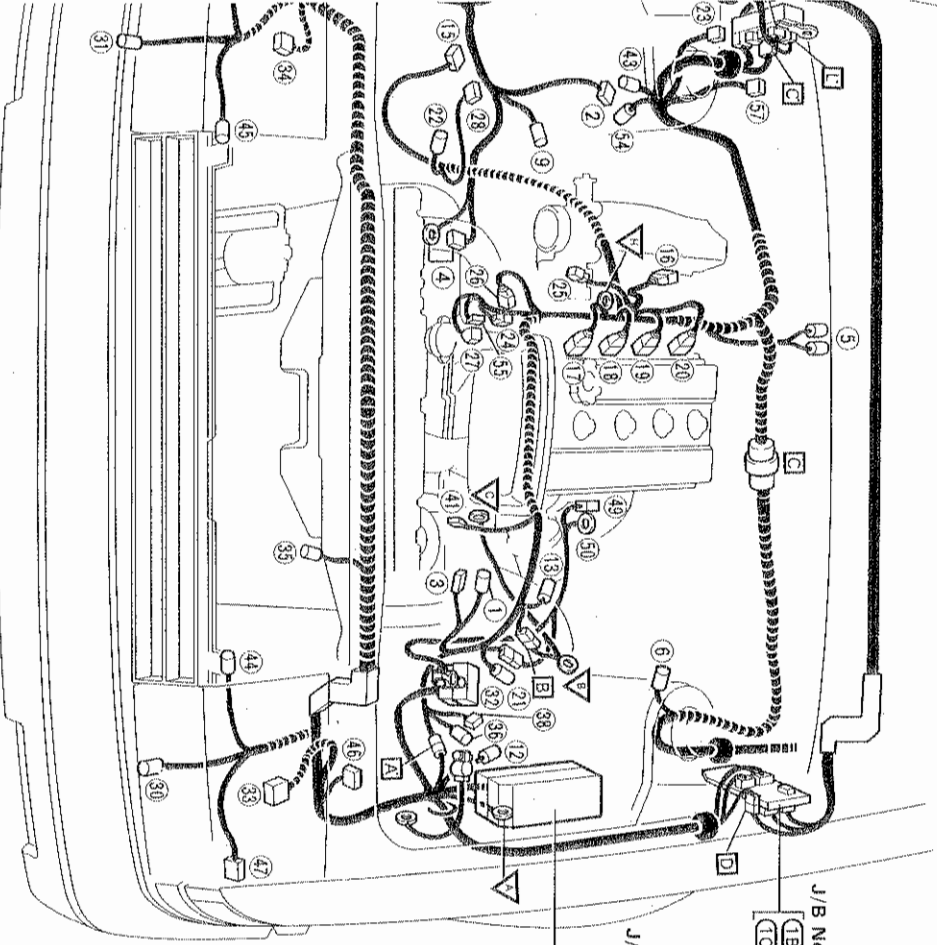

t Control Valve  
 er Motor  
 Motor LH  
 Motor RH  
 Relay  
 ar Light LH  
 ar Light RH  
 /W  
 /W (USA)  
 or  
 1p. S/W  
 om Main Wire and J/B No. 1  
 om Main Wire and J/B No. 2

- A Oil Pressure Wire and Engine Wire (4A-C Engine Front)
- A Engine Wire and Engine Room Main Wire (4A-GEC, Beside Battery)
- B Ground Wire and Engine Room Main Wire (Engine Left)
- C Cowl Wire and Engine Wire (Engine Rear)
- C Cowl Wire and Engine Wire (4A-GEC Right Kick Panel)
- D Cowl Wire and Engine Room Main Wire (Left Kick Panel)
- D Cowl Wire and Engine Room Main Wire (Right Kick Panel)
- L Ground Left Fender Apron
- M Ground Left Fender Left
- V Ground Intake Air Chamber

- 1 A/C Amplifier
- 2 A/C Electrical Idle-up Cut Relay
- 3 A/C Magnet Clutch Relay
- 4 A/C Pressure S/W
- 5 A/C S/W (or Volume S/W)
- 6 A/C Thermostat
- 7 A/T Indicator Light and O/D S/W
- 8 Blower Resistor
- 9 Blower Motor
- 10 Blower S/W
- 11 Charge Light Relay
- 12 Cigarette Lighter
- 13 Clock
- 14 Clutch S/W (or Short Pin)
- 15 Clutch Start S/W
- 16 Combination Meter
- 17 Combination S/W
- 18 Cruise Control Computer
- 19 Cruise Control Stop S/W and Stop Light S/W
- 20 Cruise Control S/W
- 21 Defogger S/W

- 23 Diode (1N)
- 24 Diode (Idle)
- 25 Diode (Idle)
- 26 EFI ECU
- 27 EFI Circuit
- 28 Emission
- 29 Front Spd
- 30 Front Spd
- 31 Ignition S
- 32 Light Cor
- 33 Light Cor
- 34 Light Ret
- 35 O/D Rela
- 36 Radio ant
- 37 Rear Wip
- 38 Rear Wip
- 39 Remote C
- 40 Retract C
- 41 Seat Belt
- 42 Starter R
- 43 Turn Sigt
- 44 Unlock W
- 45 Wiper S/W

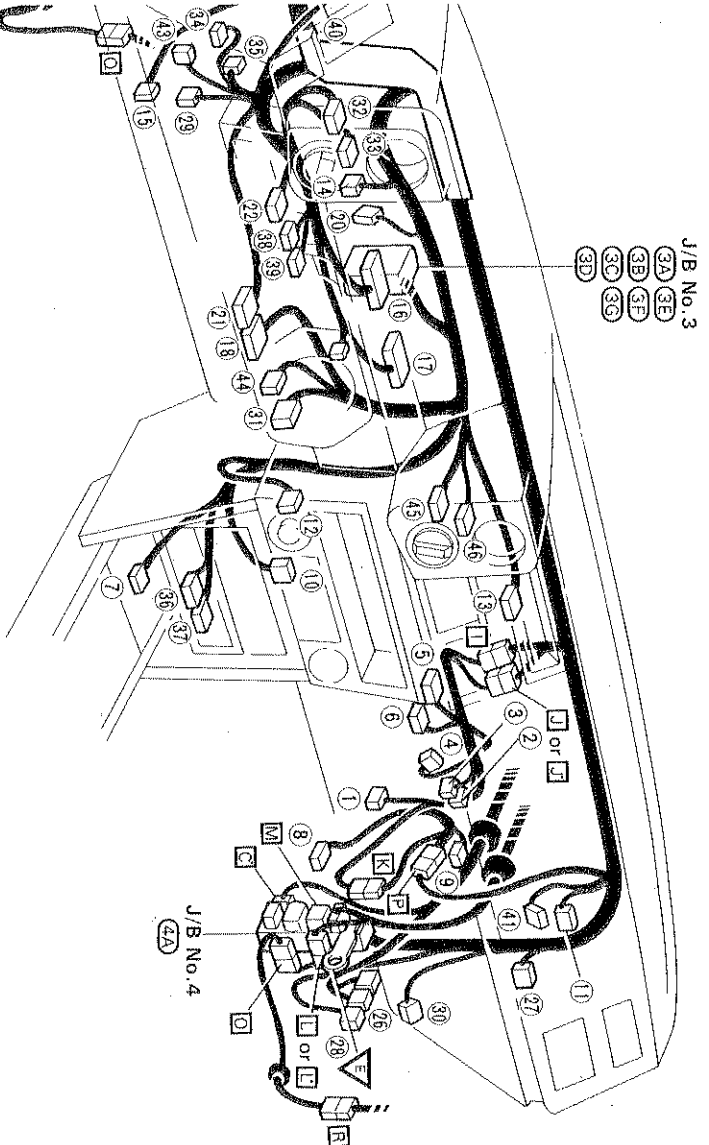

J/B No. 3  
 (2A) (3E)  
 (3B) (3E)  
 (3C) (3G)  
 (3D)

J/B No. 4  
 (4A)

[2Door]

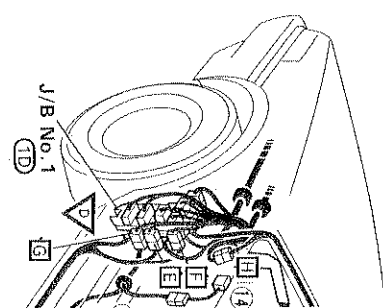

J/B No. 1  
 (1D)

- (23) Diode (INTERIOR LIGHTS)
- (24) Diode (Idle-up, Tail, Defogger)
- (25) Diode (Idle-up, Heater, Stop)
- (26) EFI ECU
- (27) EFI Circuit Opening Relay
- (28) Emission Control Computer
- (29) Front Speaker LH
- (30) Front Speaker RH
- (31) Ignition Control S/W and Rheostat
- (32) Light Control S/W Indicator Light
- (33) Light Retainer Relay
- (34) Light Relay (A/T)
- (35) O/D Relay (A/T)
- (36) Radio and Tape Player
- (37)
- (38) Rear Wiper S/W
- (39) Remote Control Mirror S/W
- (40) Retract Control Relay
- (41) Seat Belt Warning Relay
- (42) Starter Relay
- (43) Turn Signal Flasher
- (44) Unlock Warning S/W
- (45) Wiper S/W

- (46) Wiper S/W Indicator Light
- (1A) Roof Wire and J/B No. 1
- (1B) Engine Room Main Wire and J/B No. 1
- (1C) Floor Wire and J/B No. 1
- (1D)
- (1E)
- (1F) Cowl Wire and J/B No. 1
- (1G)
- (1H)
- (1I)
- (1J)
- (1K)
- (1L)
- (1M)
- (1N)
- (1O)
- (1P)
- (1Q)
- (1R)
- (1S)
- (1T)
- (1U)
- (2A) Cowl Wire and J/B No. 4
- (2B)
- (2C)
- (2D)
- (2E)
- (2F)
- (2G)
- (2H)
- (2I)
- (2J)
- (2K)
- (2L)
- (2M)
- (2N)
- (2O)
- (2P)
- (2Q)
- (2R)
- (2S)
- (2T)
- (2U)
- (2V)
- (2W)
- (2X)
- (2Y)
- (2Z)
- (3A) Cowl Wire and J/B No. 3
- (3B)
- (3C)
- (3D)
- (3E)
- (3F)
- (3G)
- (3H)
- (3I)
- (3J)
- (3K)
- (3L)
- (3M)
- (3N)
- (3O)
- (3P)
- (3Q)
- (3R)
- (3S)
- (3T)
- (3U)
- (3V)
- (3W)
- (3X)
- (3Y)
- (3Z)
- (4A) Cowl Wire and J/B No. 1
- (4B)
- (4C)
- (4D)
- (4E)
- (4F)
- (4G)
- (4H)
- (4I)
- (4J)
- (4K)
- (4L)
- (4M)
- (4N)
- (4O)
- (4P)
- (4Q)
- (4R)
- (4S)
- (4T)
- (4U)
- (4V)
- (4W)
- (4X)
- (4Y)
- (4Z)

- (E) Floor Wire and Cowl Wire (Left Kick Panel)
- (F) Left Door Wire and Cowl Wire (Left Kick Panel)
- (G) Roof Wire and Cowl Wire (Left Kick Panel)
- (H) A/C Wire and Cowl Wire (Instrument Panel Right)
- (I) Heater Wire and A/C Wire (Instrument Panel Right)
- (J) Engine Room Main Wire and Cowl Wire (Right Kick Panel)
- (K) Right Door Wire and Cowl Wire (Right Kick Panel)
- (L) Heater Wire and Cowl Wire (Instrument Panel Right)
- (M) Left Mirror Wire and Left Door Wire (Left Door Front)
- (N) Right Mirror Wire and Right Door Wire (Right Door Front)
- (O) Ground J/B No. 1 Set Bolt
- (P) Ground J/B No. 4 Set Bolt
- (Q)
- (R)
- (S)
- (T)
- (U)
- (V)
- (W)
- (X)
- (Y)
- (Z)

# ELECTRICAL WIRING R

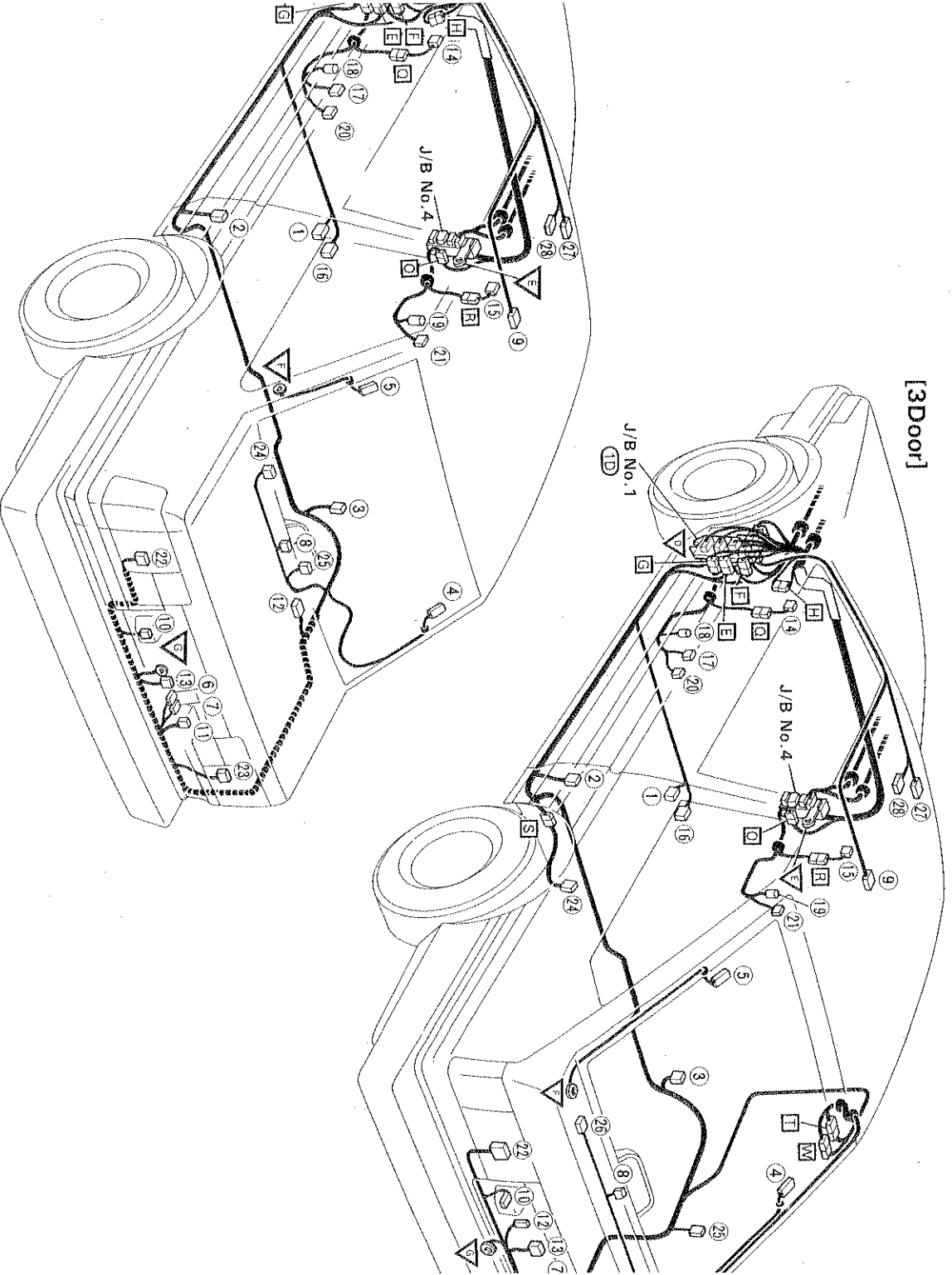

- ① Buckle S/W
- ② Courtesy S/W
- ③ Defogger ⊕
- ④ Defogger ⊖
- ⑤ Fuel Level Sender
- ⑥ Fuel Pump [4A-GEC]
- ⑦ High Mount Stop Light
- ⑧ Interior Light
- ⑨ Licence Light LH
- ⑩ Licence Light RH
- ⑪ Luggage Room Light
- ⑫ Luggage Room Light S/W
- ⑬ Mirror Motor LH
- ⑭ Mirror Motor RH
- ⑮ Parking Brake S/W
- ⑯ Power Window Master S/W
- ⑰ Power Window Motor
- ⑱ Power Window Relay
- ⑳ Power Window S/W

- ⑳ Rear Combination Light LH
- ㉑ Rear Combination Light RH
- ㉒ Rear Speaker LH
- ㉓ Rear Speaker RH
- ㉔ Rear Wiper Motor
- ㉕ Sun Roof and Map Light S/W
- ㉖ Sun Roof Motor
- ㉗ Floor Wire and J/B No. 1
- ㉘ Floor Wire and Cowl Wire
- ㉙ (Left Kick Panel)
- ㉚ Left Door Wire and Cowl Wire
- ㉛ (Left Kick Panel)
- ㉜ Roof Wire and Cowl Wire
- ㉝ (Left Kick Panel)
- ㉞ Right Door Wire and Cowl Wire
- ㉟ (Right Kick Panel)
- Ⓚ Left Mirror Wire and Left Door Wire
- Ⓛ Left Door Front
- Ⓜ Right Mirror Wire and Right Door Wire
- Ⓨ Right Door Front
- Ⓩ Rear Speaker Wire and Floor Wire
- ⓓ (3 Door C/P, Rear Seat Left)

- Ⓣ Back Door No. 1 Wire and Floor Wire
- (3 Door C/P, Roof Right Rear)
- Ⓤ Back Door No. 2 Wire and Back Door No. 1 Wire
- (3 Door C/P, Back Door Right)
- Ⓥ Defogger Wire and Back Door No. 1 Wire
- (3 Door C/P, Back Door Right)
- Ⓦ Back Door No. 2 Wire and Back Door No. 1 Wire
- (3 Door C/P, Back Door Right)
- Ⓧ Ground J/B No. 1 Set Bolt
- Ⓨ Ground J/B No. 4 Set Bolt
- Ⓩ Ground Left Rear Pillar (2 Door C/P)
- ⓐ Ground Back Door Left (3 Door C/P)
- ⓑ Ground Back Panel Center

# ELECTRICAL WIRING ROUTING

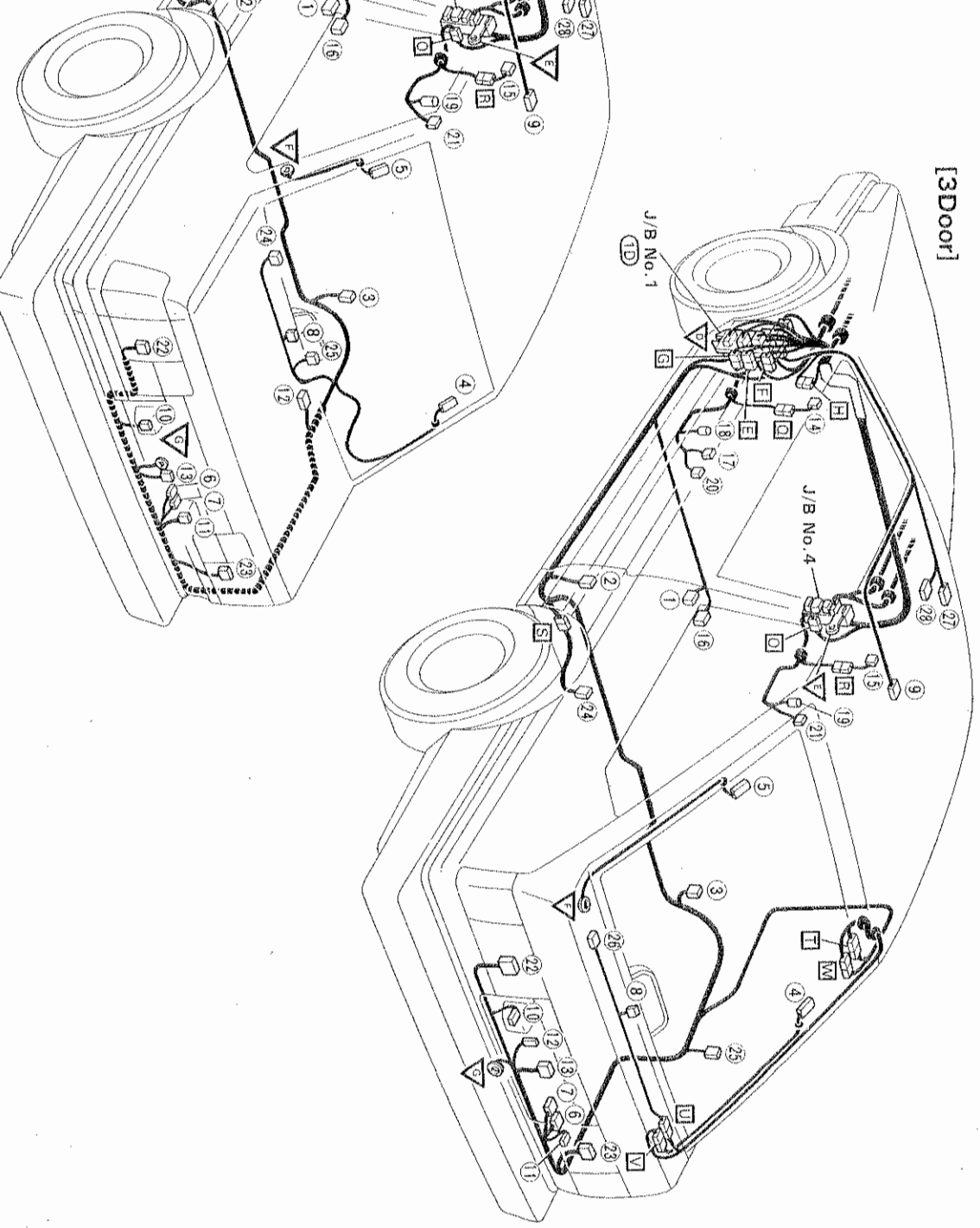

- 22 Rear Combination Light LH
- 23 Rear Combination Light RH
- 24 Rear Speaker LH
- 25 Rear Speaker RH
- 26 Rear Wiper Motor
- 27 Sun Roof and Map Light S/W
- 28 Sun Roof Motor
- 29 Floor Wire and J/B No. 1
- 30 Floor Wire and Cowl Wire
- (D) Left Kick Panel
- (E) Left Door Wire and Cowl Wire
- (F) Left Kick Panel
- (G) Roof Wire and Cowl Wire
- (H) Left Kick Panel
- (I) Right Door Wire and Cowl Wire
- (J) Right Kick Panel
- (K) Left Mirror Wire and Left Door Wire
- (L) Left Door Front
- (M) Right Mirror Wire and Right Door Wire
- (N) Right Door Front
- (O) Rear Speaker Wire and Floor Wire
- (P) 3 Door C/P, Rear Seat Left





























- T Back Door No. 1 Wire and Floor Wire
- (3 Door C/P, Roof Right Rear)
- U Back Door No. 2 Wire and Back Door No. 1 Wire
- (3 Door C/P, Back Door Right)
- V Defogger Wire and Back Door No. 1 Wire
- (3 Door C/P, Back Door Right)
- W Back Door No. 2 Wire and Back Door No. 1 Wire
- (3 Door C/P, Back Door Right)
- X Ground J/B No. 1 Set Bolt
- (3 Door C/P, Back Door Right)
- Y Ground J/B No. 4 Set Bolt
- (2 Door C/P)
- Z Ground Left Rear Pillar (3 Door C/P)
- (3 Door C/P)
- AA Ground Back Panel Center

- W
- 3AA-GEC
- Stop Light
- Light
- Light RH
- Light LH
- Light S/W
- Low Master S/W
- Low Motor
- Low Relay
- Low S/W

# SYSTEM INDEX

COROLLA FR

1986 Model (Page 1 to Page 4)

| SYSTEMS                            | LOCATION  | SYSTEMS                      | LOCATION  |
|------------------------------------|---|------------------------------|---|
| Air Conditioner, Cooler and Heater |  2-1 | Radio and Tape Player        |  4-3 |
| Back-up Lights                     |  2-5 | Rear Window Defogger         |  2-6 |
| Charging                           |  1-6 | Rear Wiper and Washer        |  3-3 |
| Cigarette Lighter                  |  4-2 | Remote Control Mirrors       |  4-4 |
| Clock                              |  4-2 | Starting                     |  1-1 |
| Combination Meter                  |  2-3 | Stop Lights                  |  3-2 |
| Cruise Control                     |  3-1 | Sun Roof                     |  2-7 |
| EFI                                |  1-3 | Taillights and Illumination  |  3-6 |
| Emission Control                   |  1-7  | Turn Signal and Hazard       |  2-7  |
| Front Wiper and Washer             |  3-4   | Unlock and Seat Belt Warning |  2-5   |
| Headlights                         |  3-8   |                              |   |
| Horn                               |  2-8   |                              |   |
| Idle-up                            |  4-5   |                              |   |
| Ignition                           |  1-5   |                              |   |
| Interior Lights                    |  4-1   |                              |   |
| Overdrive                          |  2-6   |                              |   |
| Power Source                       |  1-1   |                              |   |
| Power Windows                      |  4-6    |                              |   |

# COROLLA *FR* ELECTRICAL WIRING DIAGRAM-1986 Model (Page 1 of 2)

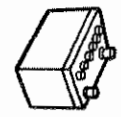

Power Source

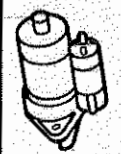

Starting

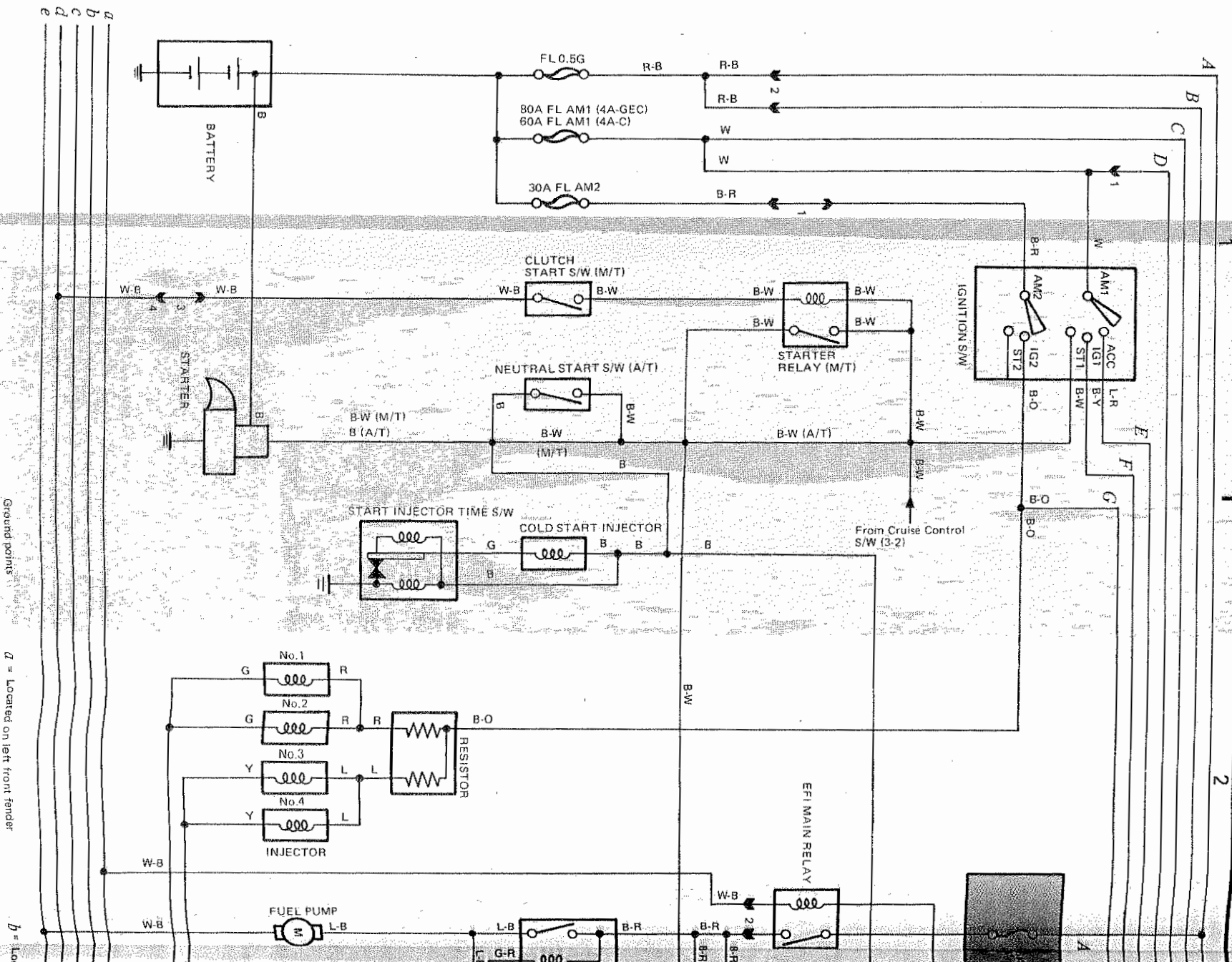

Ground points

a = Located on left front fender

b = Located on left front fender



EPI

3

4

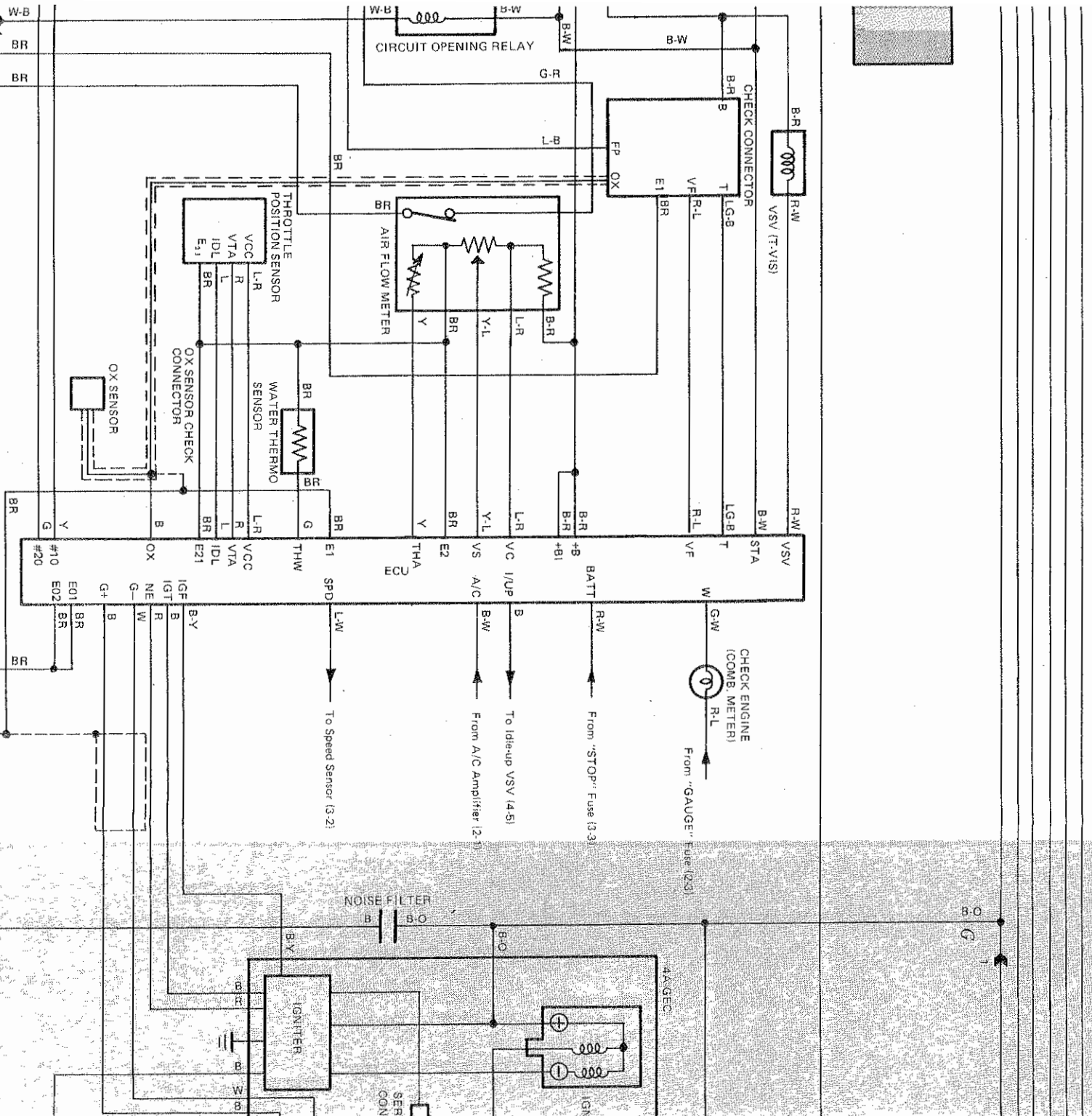

and on left side of engine block

c = Located under right front pillar

d = Located under left front pillar

e = Located on center of back panel



Ignition

5



Charging

6

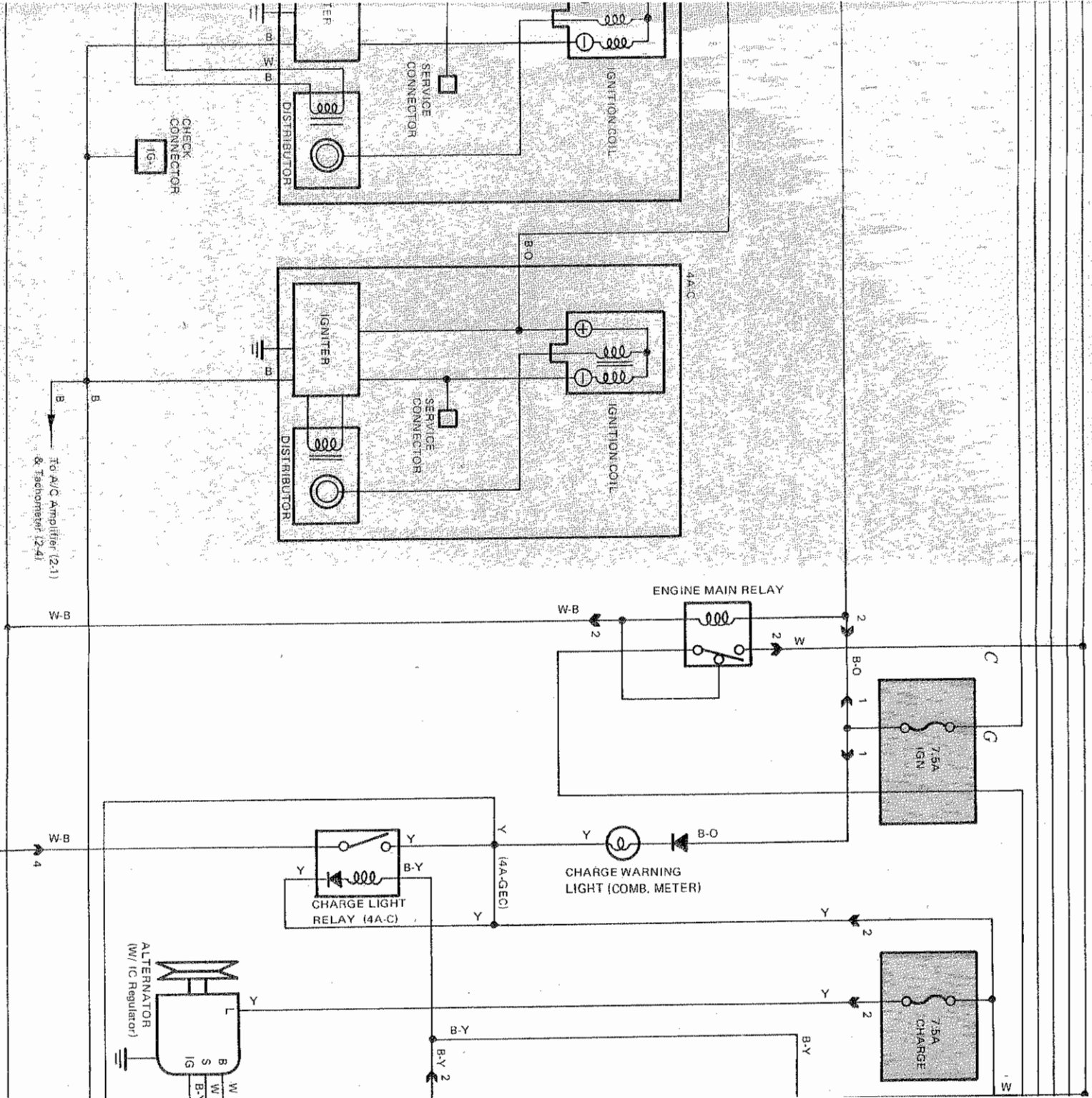



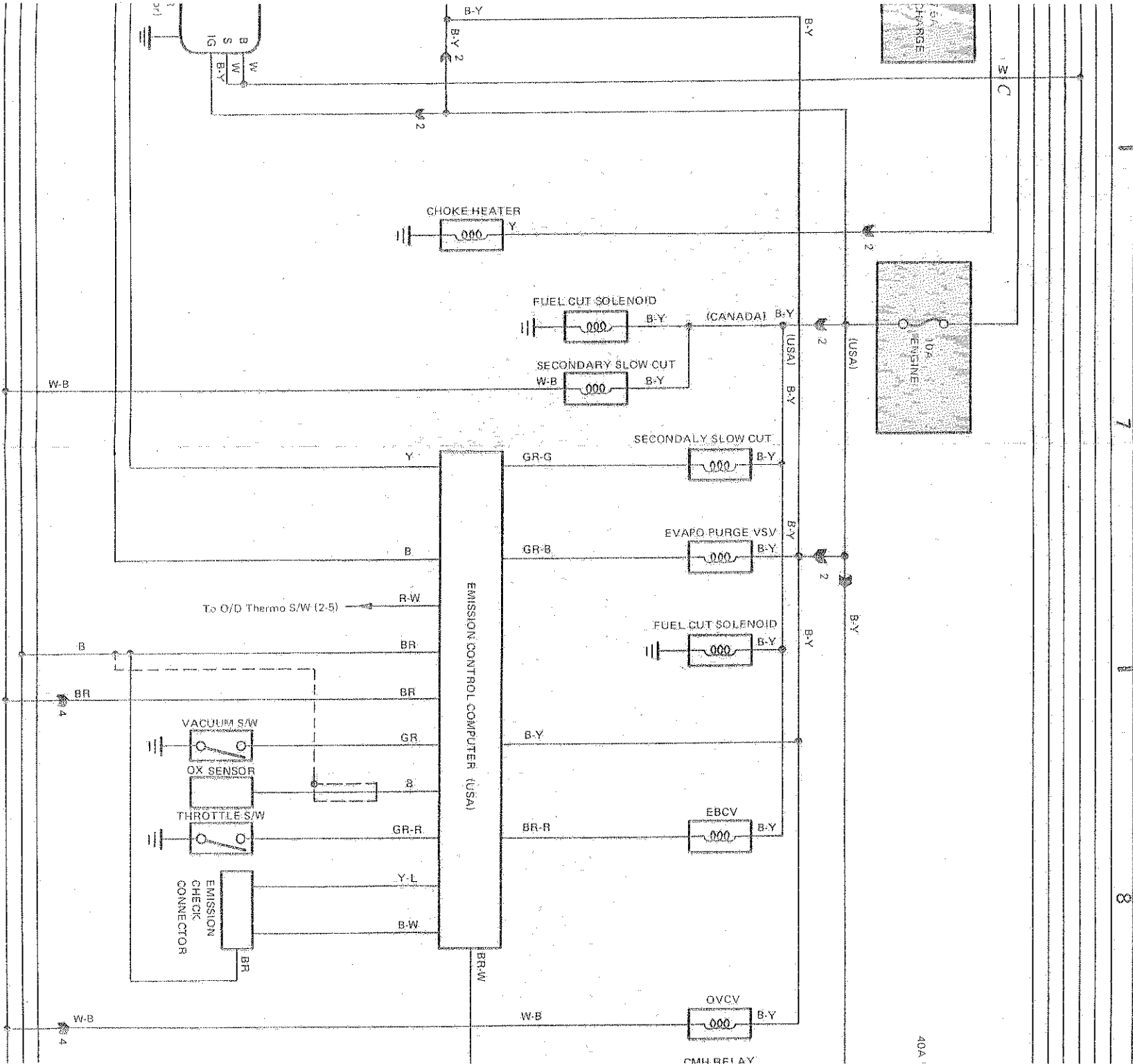

Emission Control

7

8



Emission Control

8

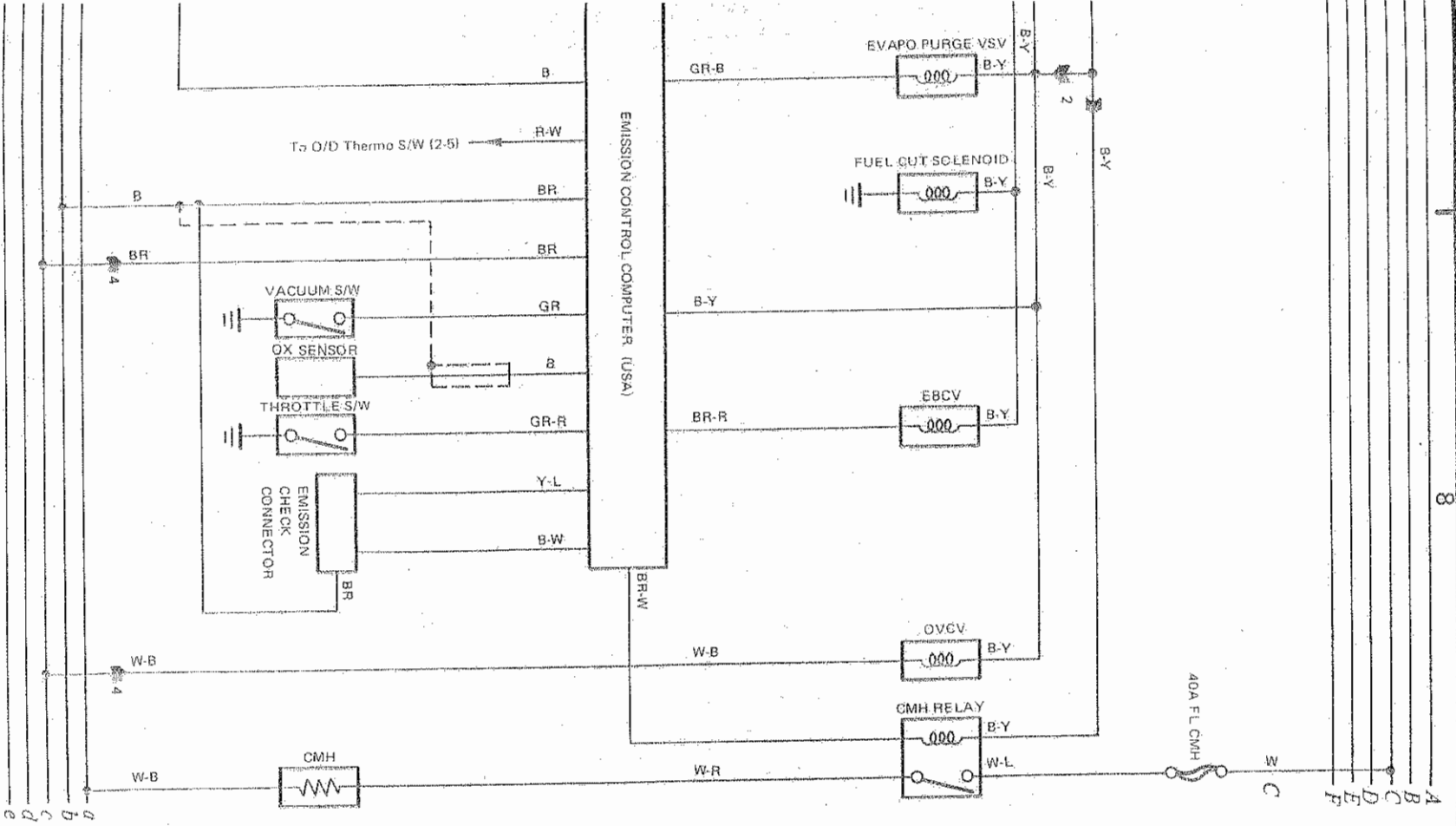



Air Conditioner, Cooler and Heater

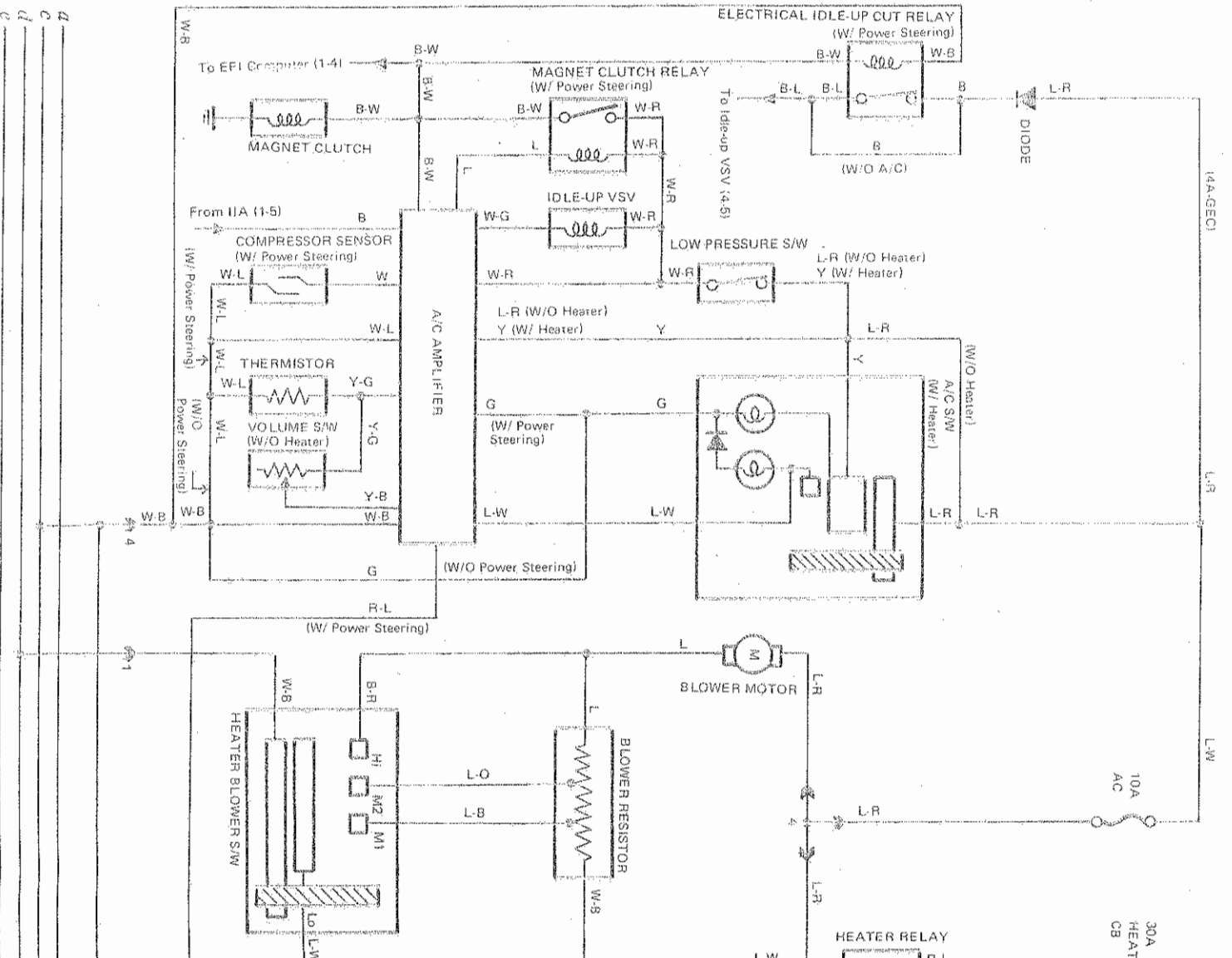
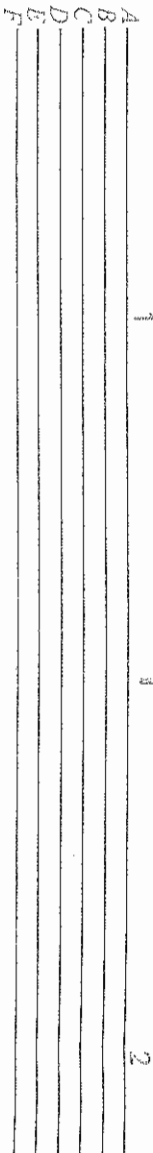

d - Located on left front fender

c - Located under right front pillar

d - Located un

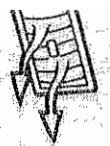

Air Conditioner, Cooler and Heater

2

3

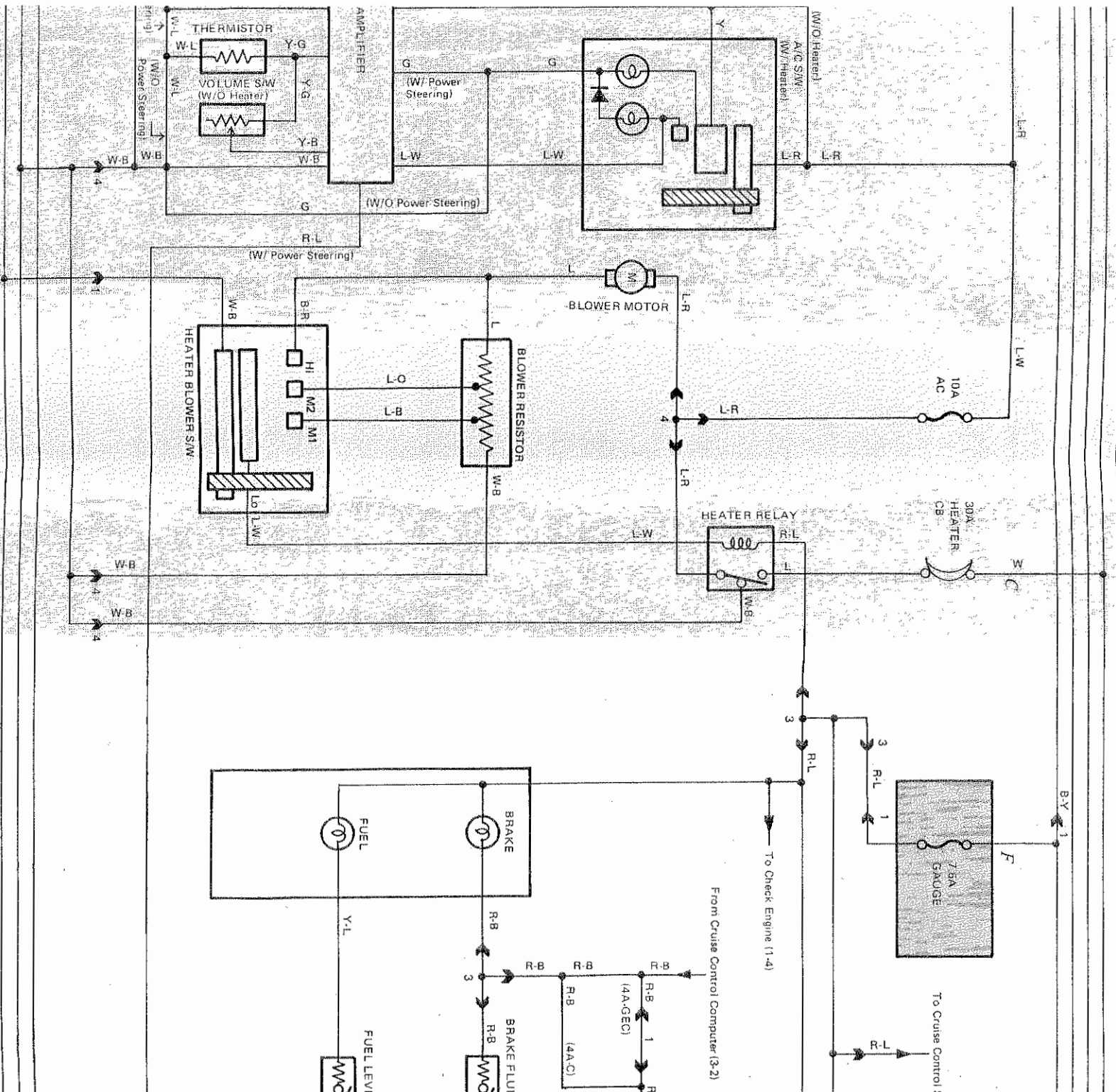

C = Located under right front pillar

d = Located under left front pillar

e = Located on center of back panel



Combination Meter

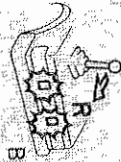

Back-up Lights



3 4

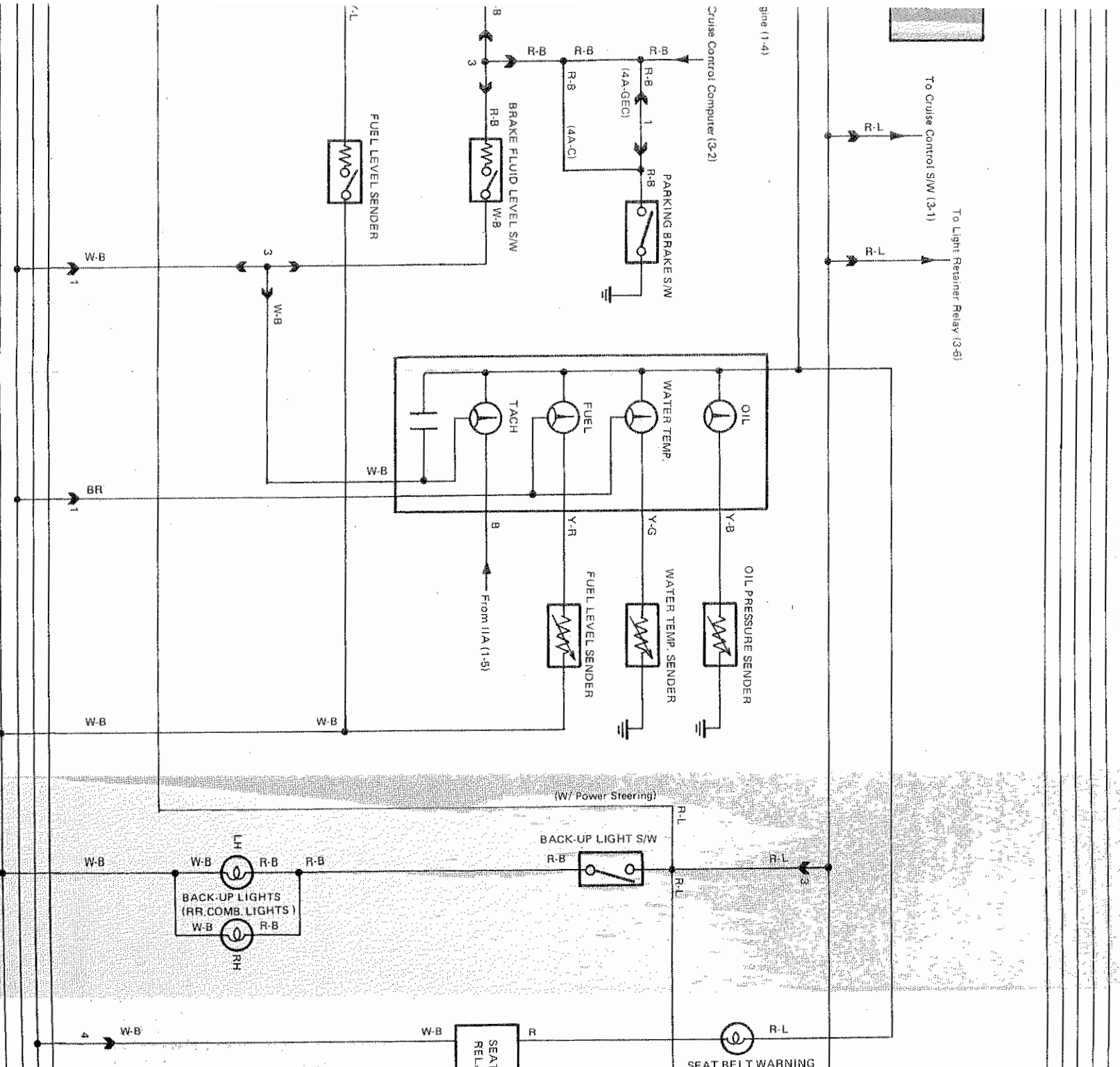

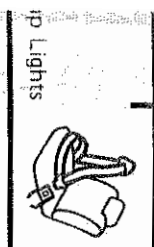
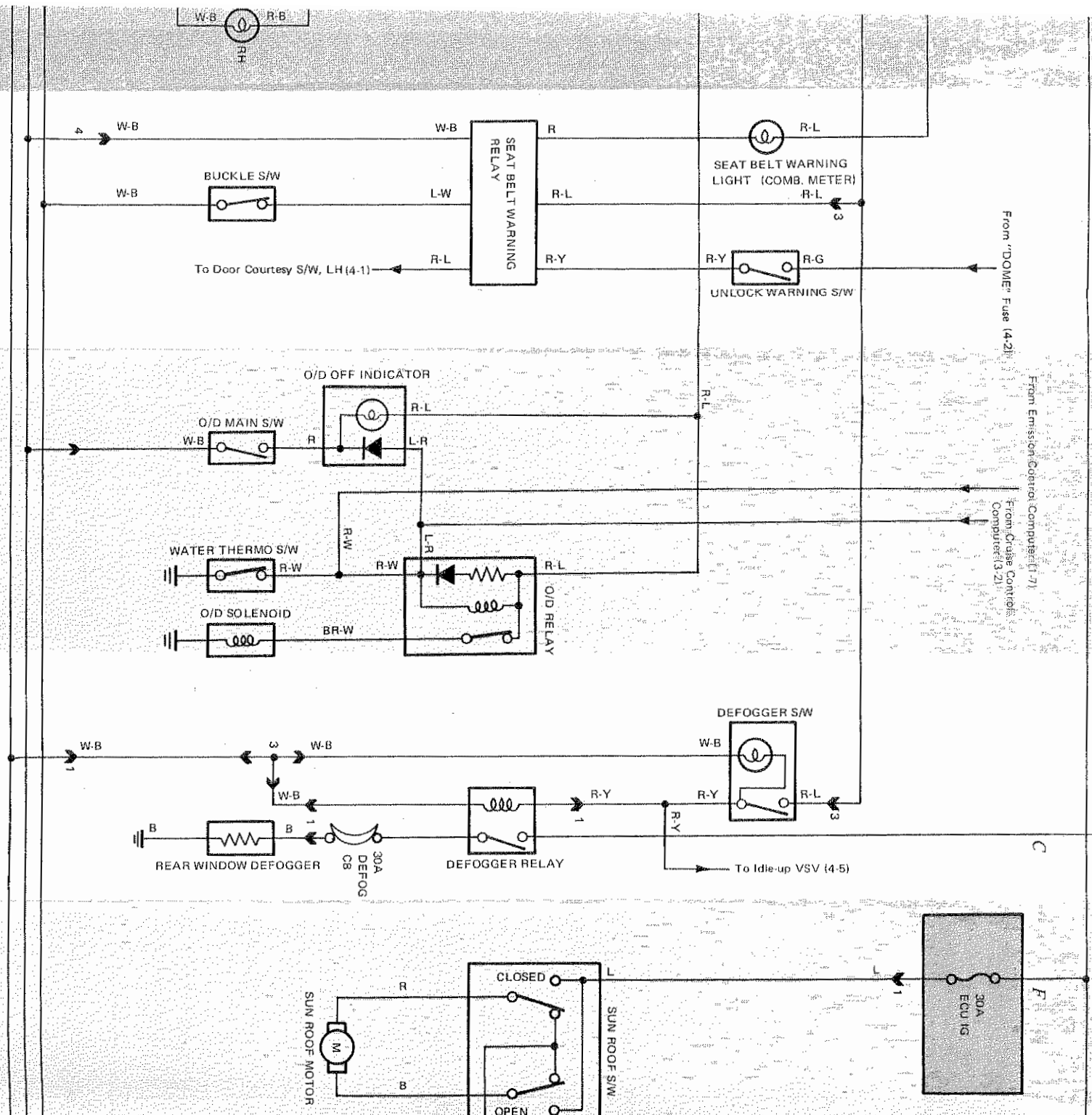

Unlock and Seat Belt Warning



Overdrive

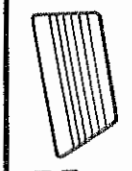

Rear Window Defogger



Sun Roof

5  
6  
F

From "DOMER" Fuse (4-2)

From Emission Control Computer (1-7)  
From Cruise Control Computer (3-2)

SEAT BELT WARNING LIGHT (COMB. METER)

UNLOCK WARNING S/W

O/D OFF INDICATOR

O/D MAIN S/W

WATER THERMO S/W

O/D SOLENOID

O/D RELAY

DEFOGGER S/W

REAR WINDOW DEFOGGER

DEFOGGER RELAY

SUN ROOF MOTOR

SUN ROOF S/W

30A ECU IG

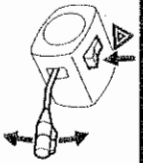

Turn Signal and Hazard



Horn

7

8

A  
B  
C  
D  
E  
F

a  
b  
c  
d  
e

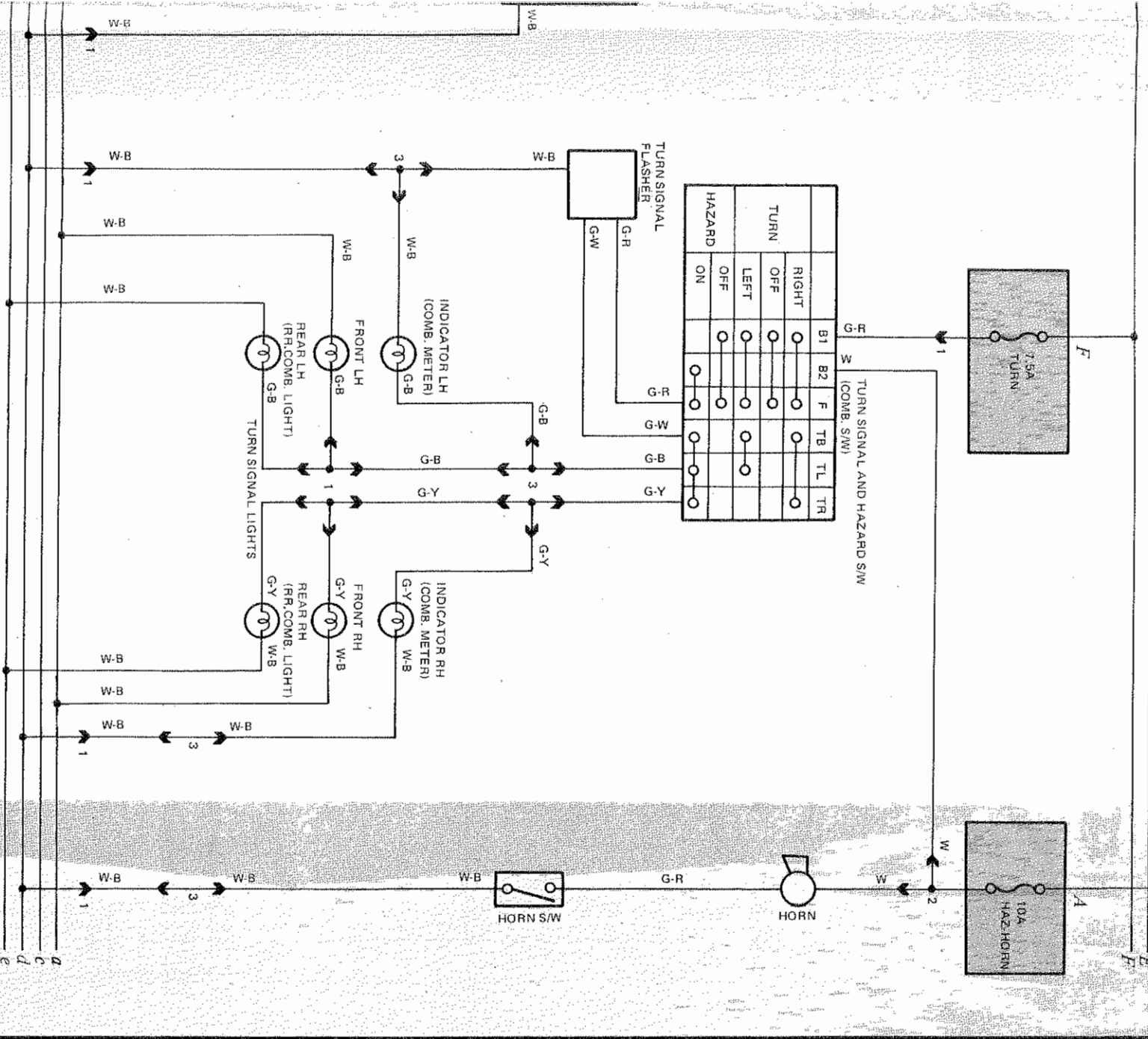

# COROLLA FR (Cont'd)



Cruise Control

A  
B  
C  
D  
E  
F

1

2

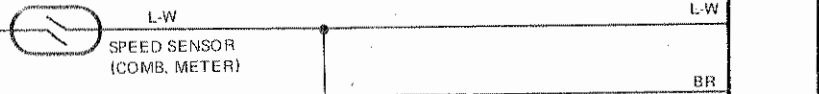
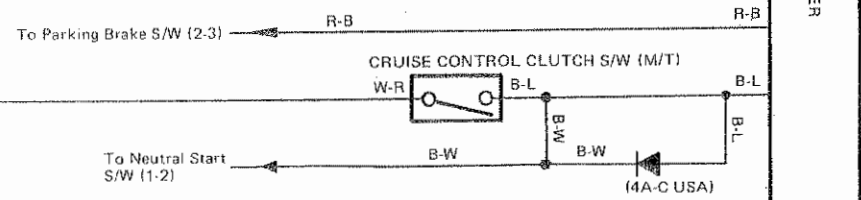
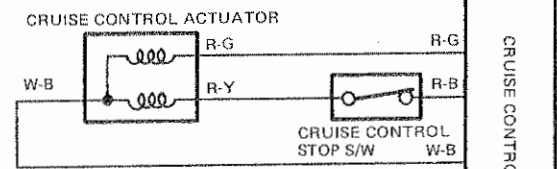
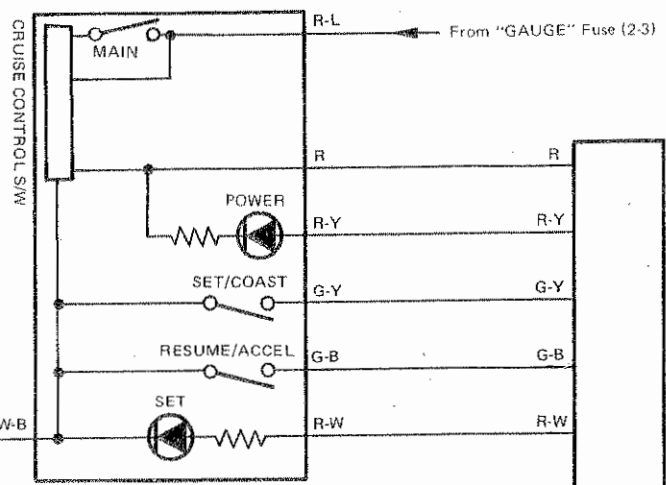

To O/D Relay (2-5)

a  
c  
d  
e

Ground points

a = Located on left front fender

c = Located under right front pillar

d = Located under left front pillar

W-B W-B LH





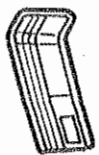

Tailights and Illumination

5

6

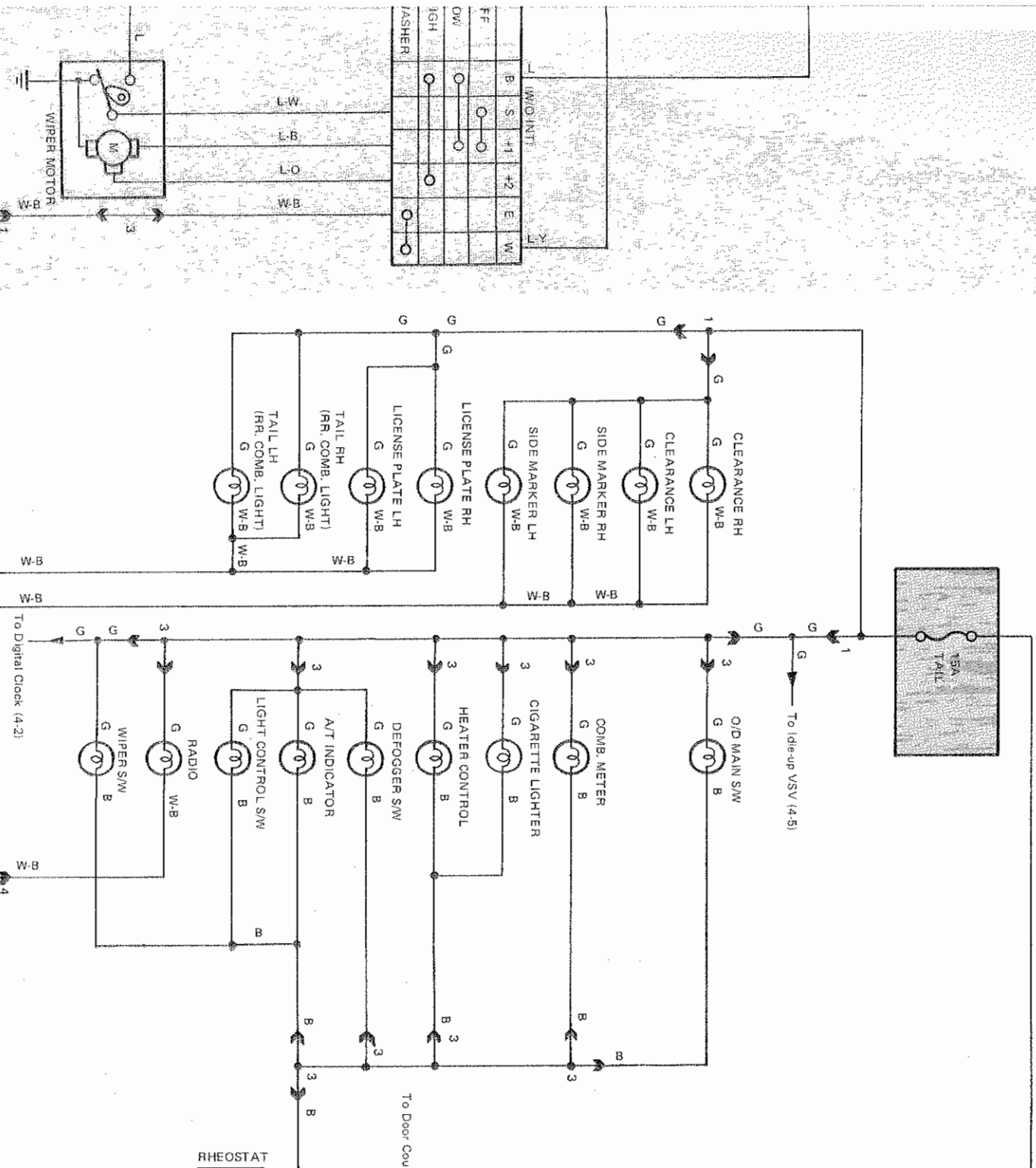



Headlights

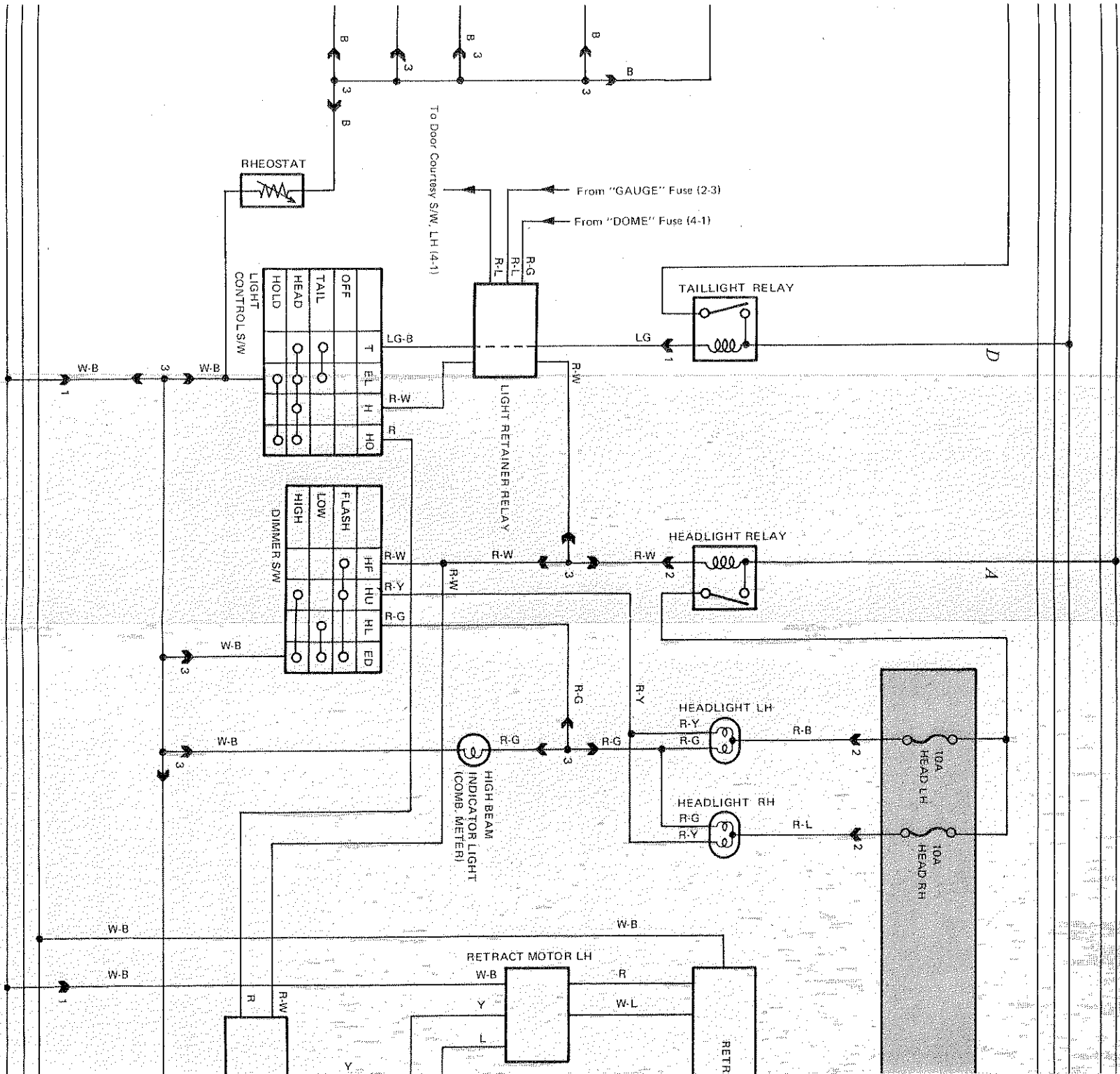



Headlights

7  
8  
A  
D  
E  
F

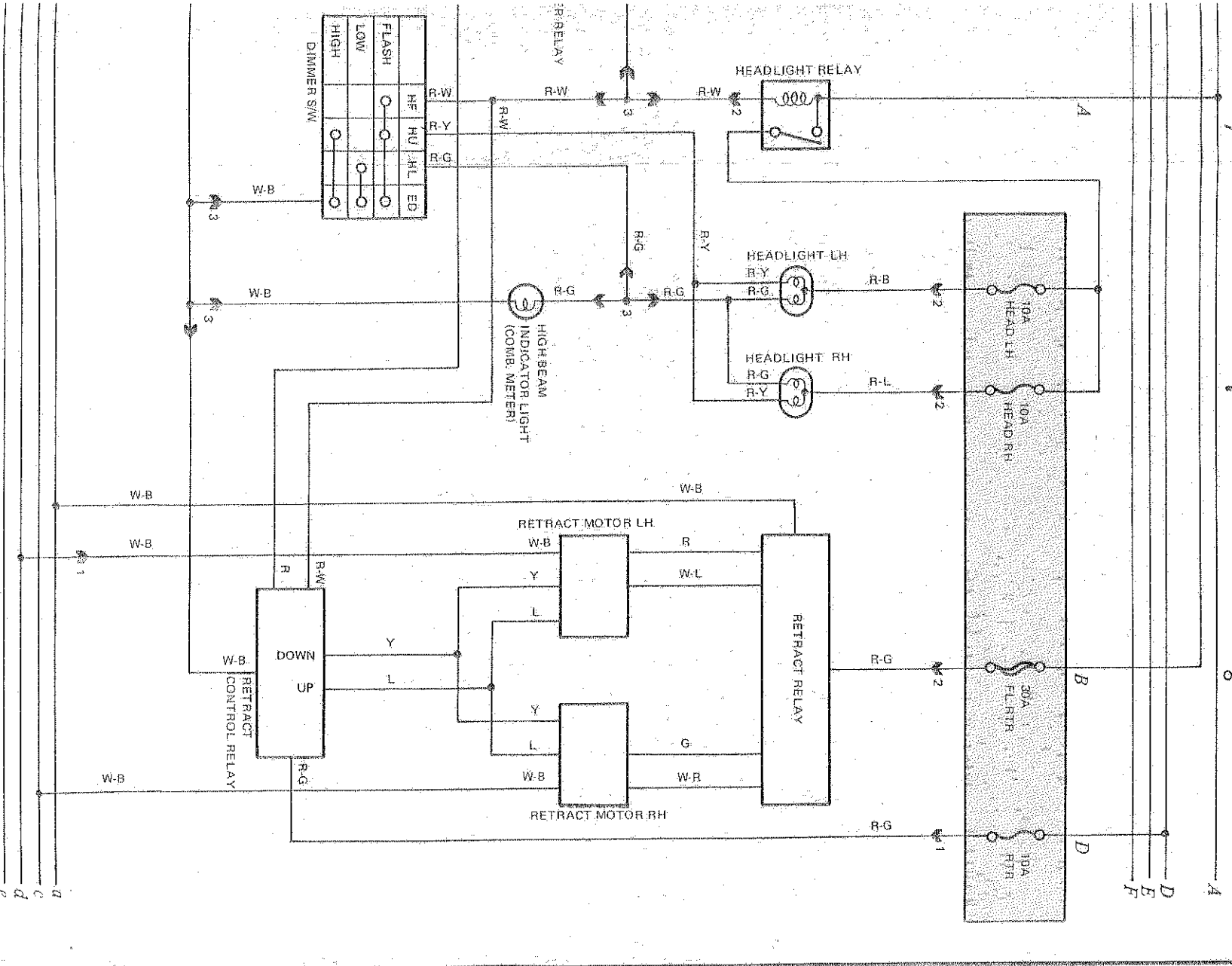



Interior Lights

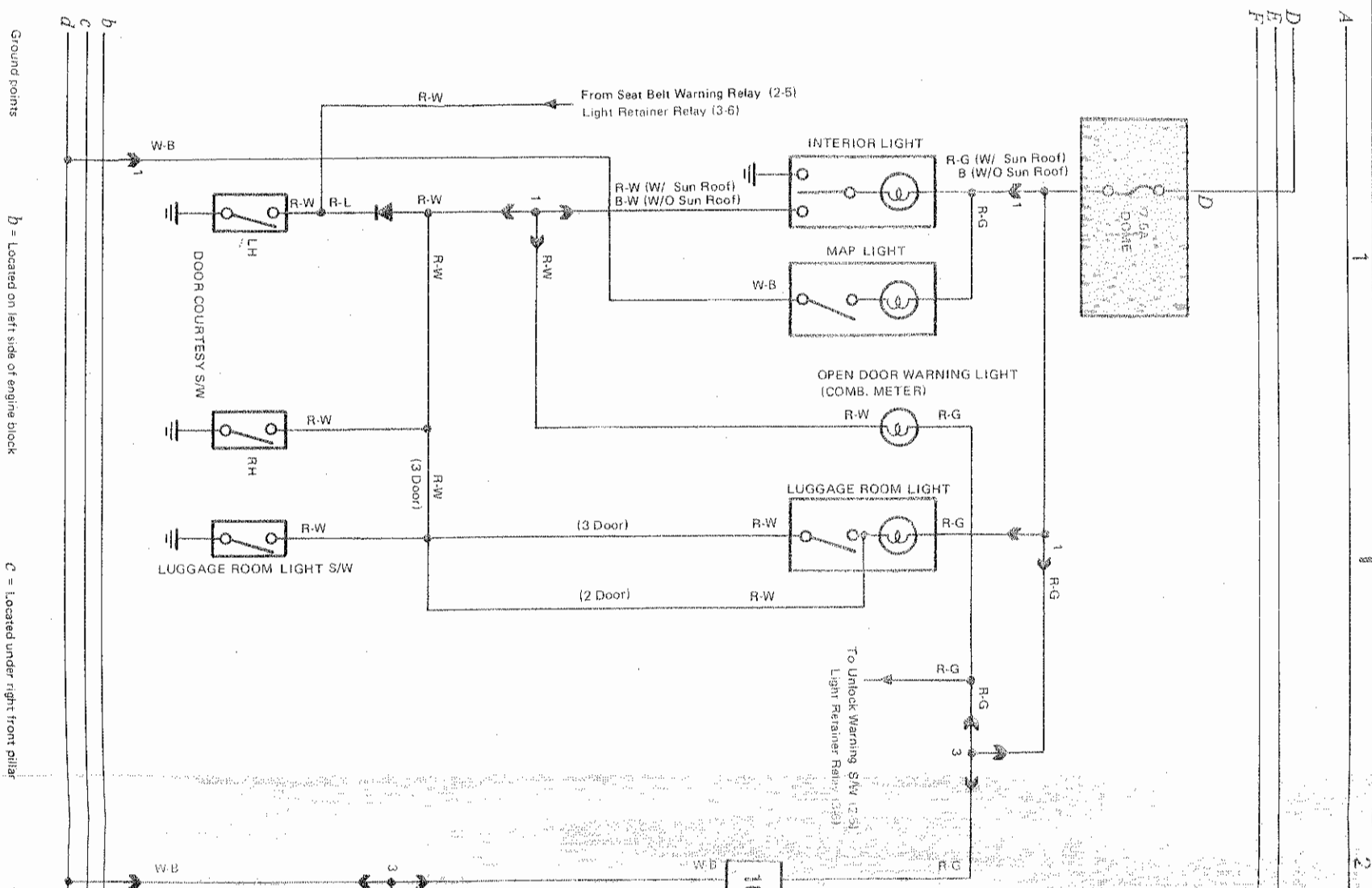

Ground points

b = Located on left side of engine block

C = Located under right front pillar



Interior Lights



Clock



Cigarette Lighter

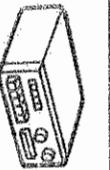

Radio

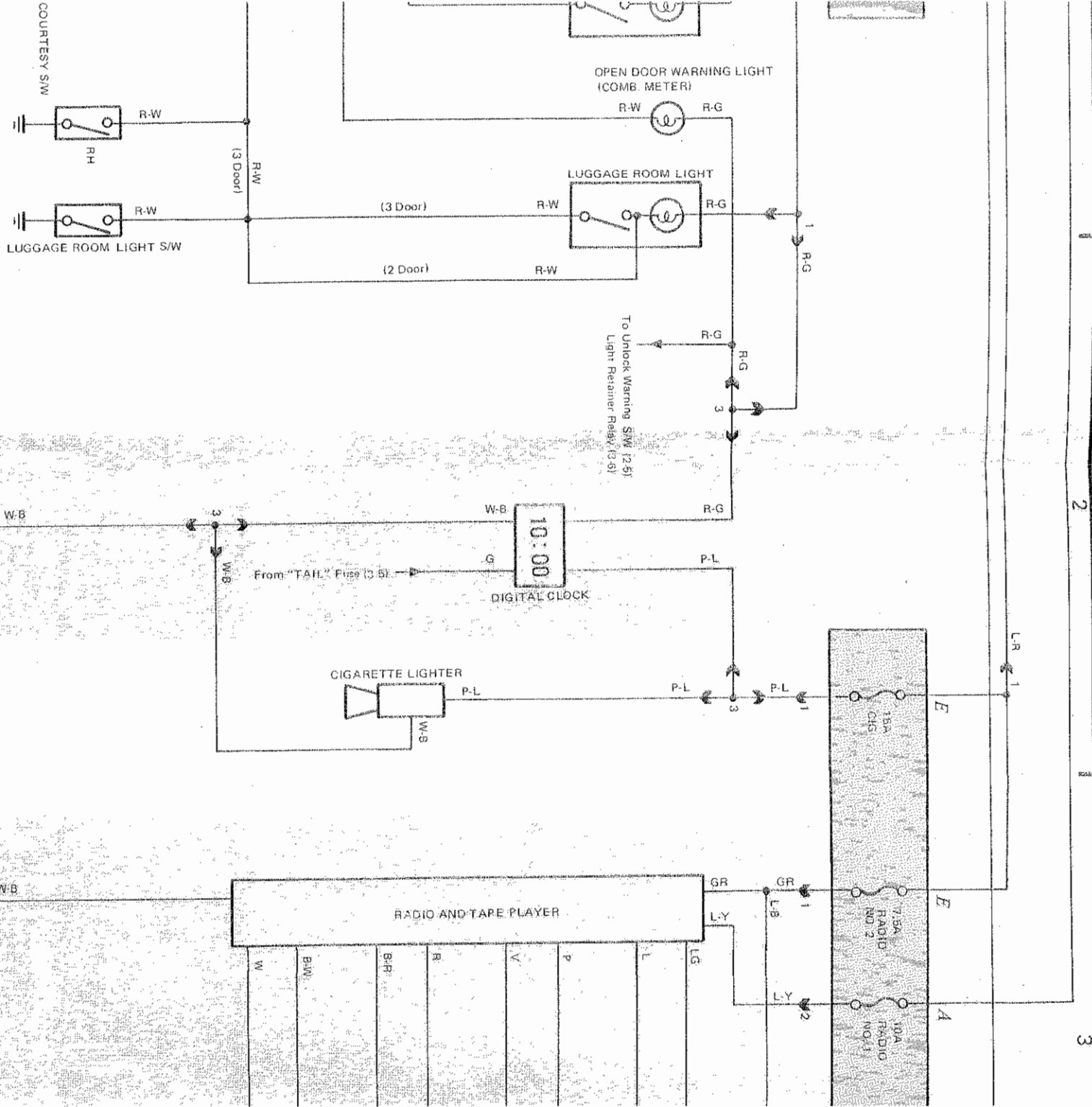

on left side of engine block

C = Located under right front pillar

C = Located under left front pillar

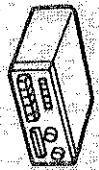

Radio and Tape Player

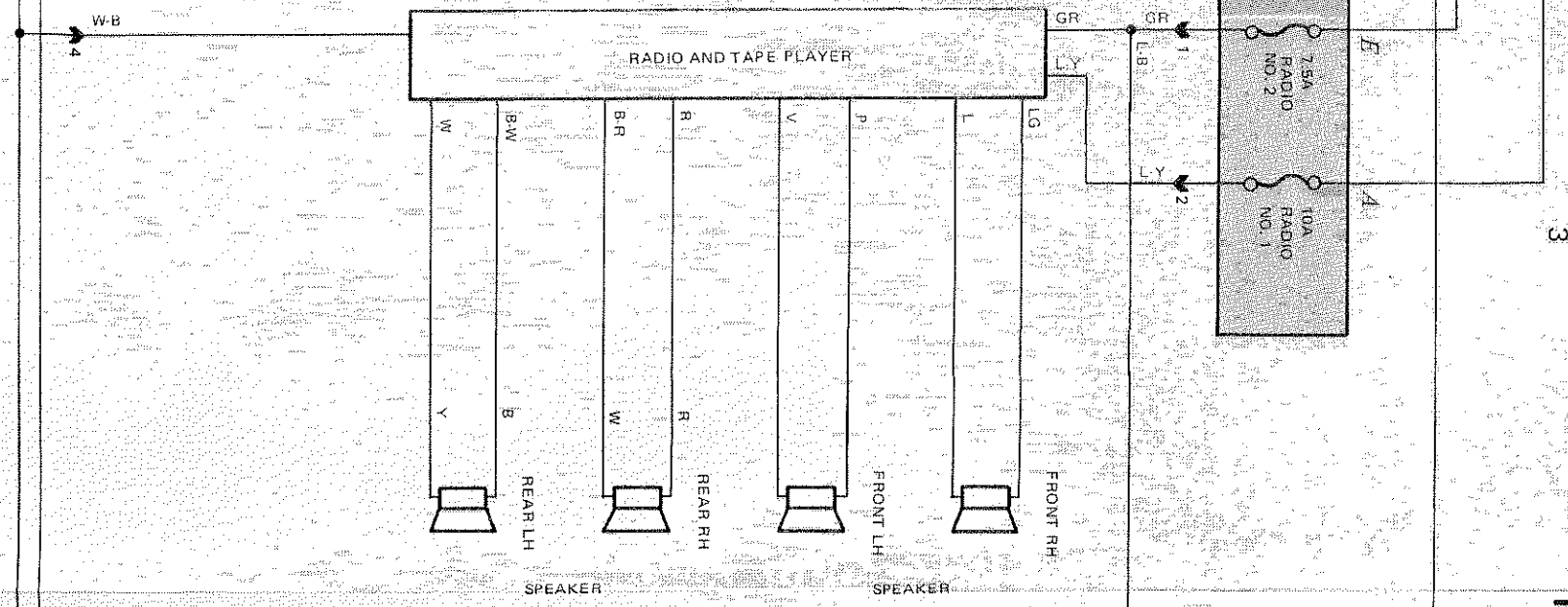

3

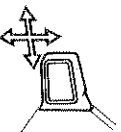

Remote Control Mirrors

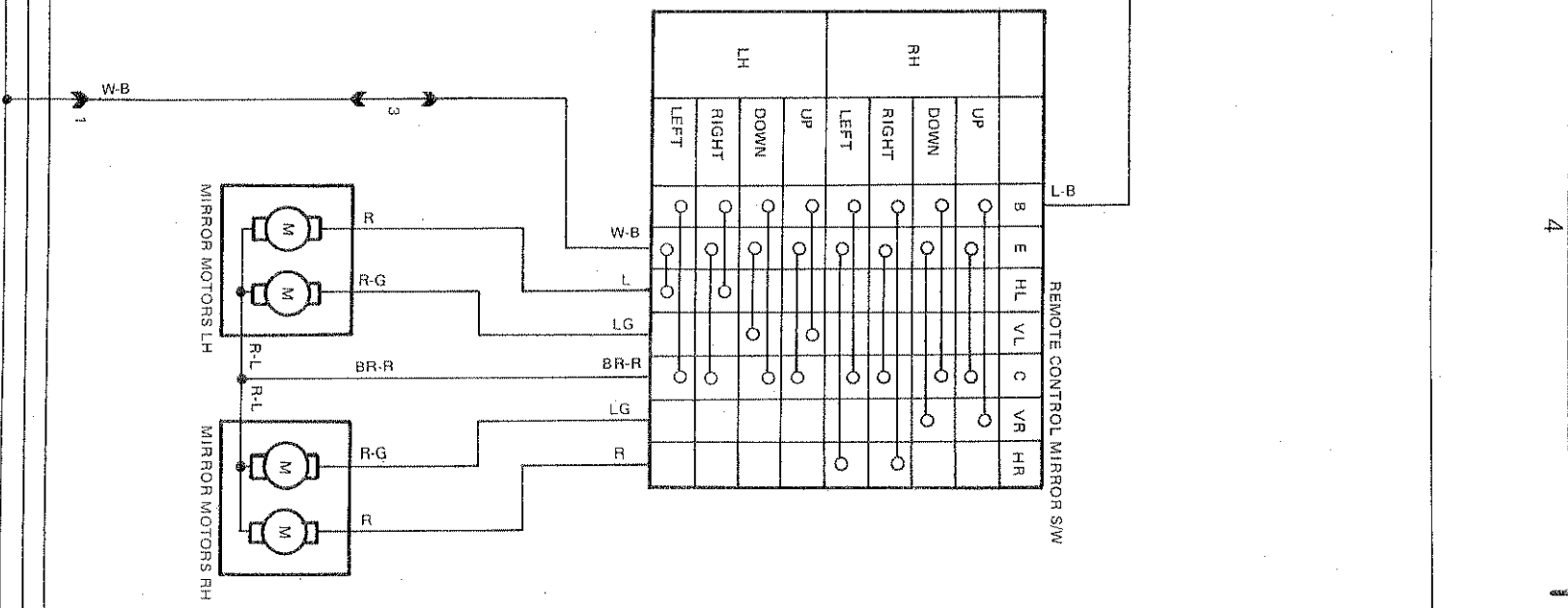

4

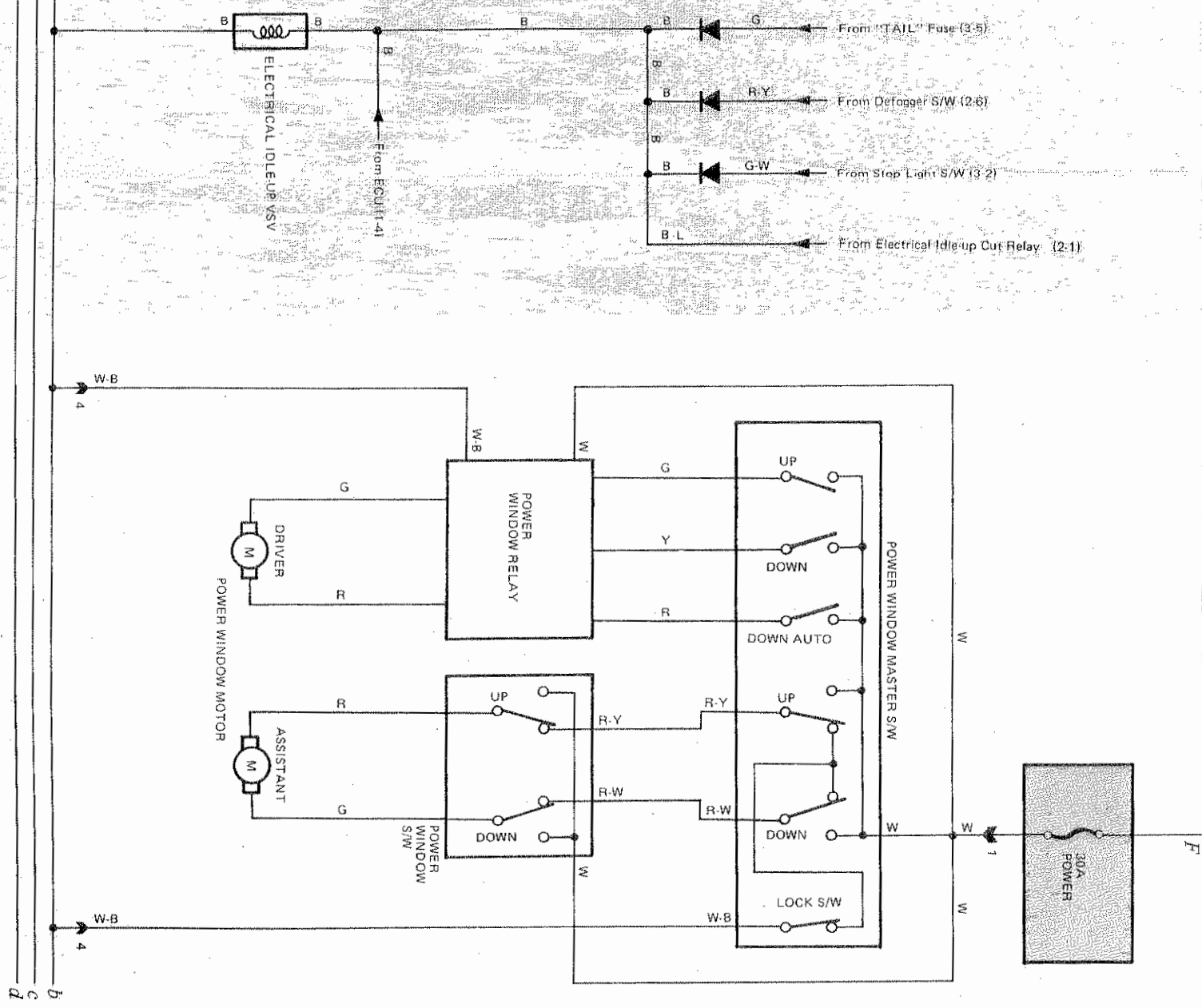

5



Idle-up

6

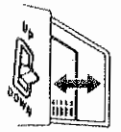

Power Windows